

# Kolibri

- Kolibri applications 19
- Kolibri dimensions 20
- Kolibri types 21
- Kolibri sizes 22
- Kolibri height 10 23
- Kolibri height 15 24
- Kolibri height 22 26
- Kolibri height 30 28
- Kolibri height 40 33
- Kolibri height 50 35
- Kolibri height 65 37
- Kolibri parts 39
- Kolibri assembly 40
- Kolibri flange connect. 42
- Kolibri part numbers 44



closed + open

## Kolibri CHARACTERISTICS

The inexpensive energy chain for light-weight applications. The patented opening offers high rigid torsion behaviour and comfortable handling in one.

- easy access by flap stays
- extremely rigid and wear resistant
- unique separation with the pinch stay
- smallest dimensions

All HELU plastic energy chains are equipped with integrated connectors. Additional mounting parts are not needed.

### Dimensions

bending radii:	15	to	400 mm
inner height:	7	to	50 mm
inner width:	7	to	195 mm
weight:	0.06	to	2.7 kg/m

### Travel distance

The maximum travel distance is given by the arrangement and the load (weight of the lines). At normal arrangements the maximum travel distance is double the free carrying length. Support rollers or similar equipment may exceed this value.

In gliding arrangements travel distances up to 100 m are possible (according to the application).

For longer travels see chapter on design guidelines.

### Travel speed

There are no limits for the travel speed in general. But with gliding arrangements application specific influences have to be taken into account.

### Acceleration

There are no limits for the accelerations, in general. Limits may occur through the tensile stresses at high line weights.

### Temperature

Long term temperature limits are between -20°C and 100°C.

### Special variants

ELTOLA	... silent running
ATEX	... EX-protection
ESD	... antistatic
V-0	... self extinguishing

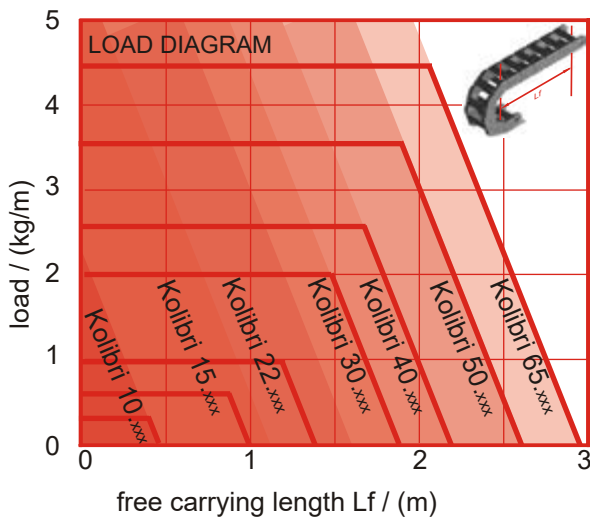

### APPLICATION AREAS

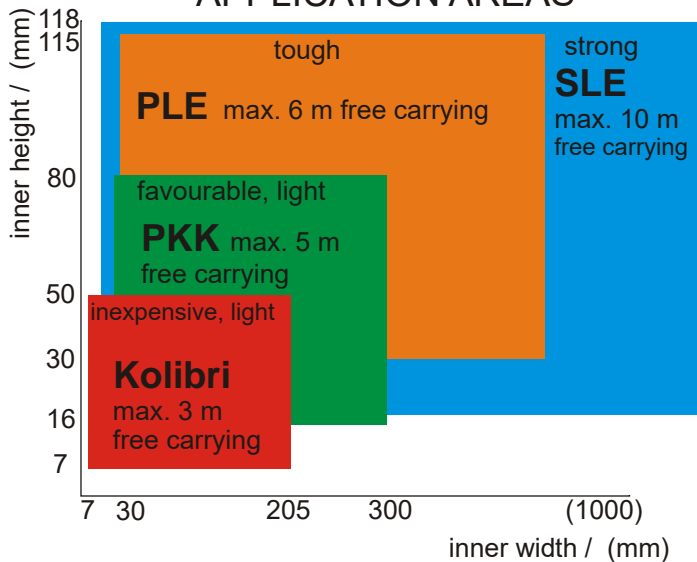

# Kolibri APPLICATIONS

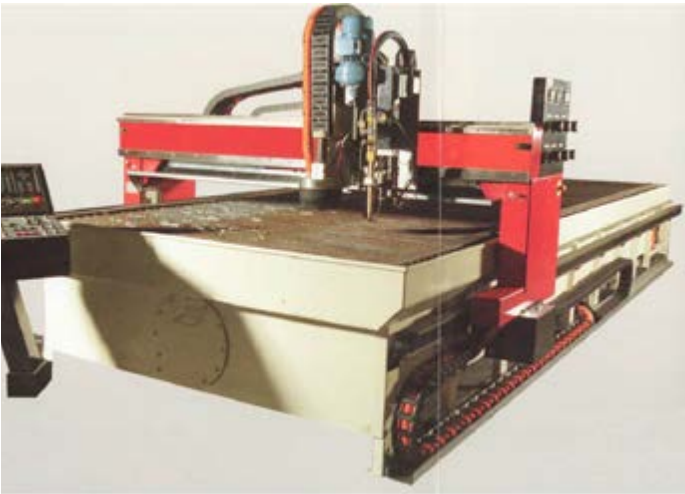
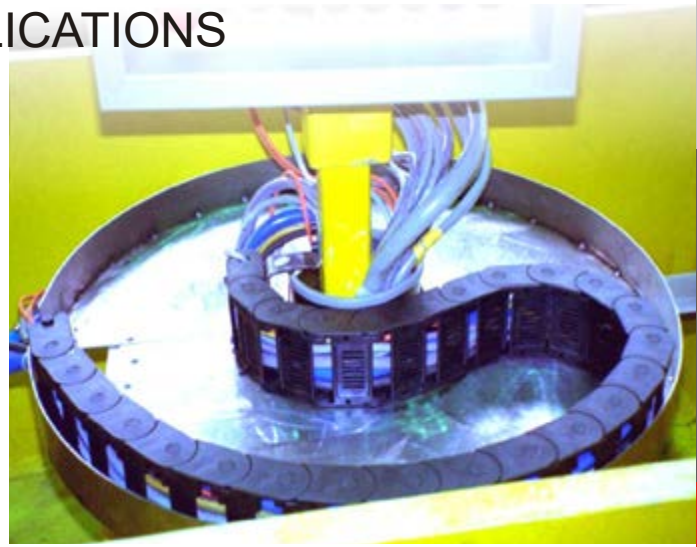

robotics, handling,  
transportation, paper production,  
textile industries, water plants





# Kolibri DIMENSIONS

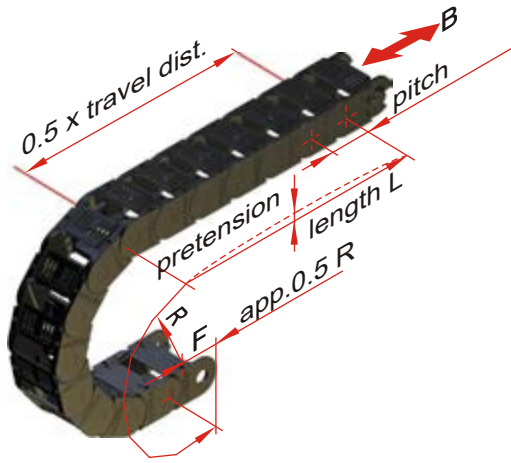
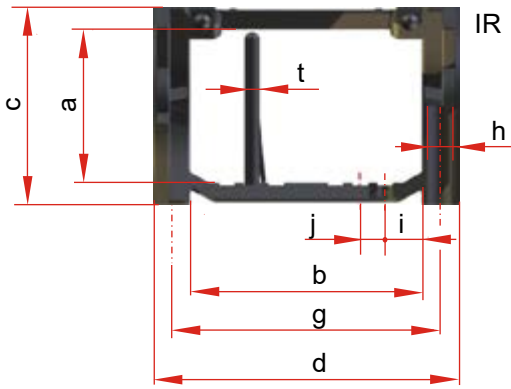

Kolibri c . d .type	prev. name		pitch	dimensions								weight kg/m
				a	b	c	d	g	h	i <sup>1)</sup>	j <sup>1)</sup>	
10.012.4	00.3		15	Ø7	10	12	12	3	-	-	-	0.05
13.023.4			20	9 14	13	23	19	3	-	-	-	0.12
15.015.3	.4	0	0.3	20	Ø10	15	15	15	4	-	-	0.15
15.036.5		02.5	18	10 25	15	36	30	4	-	-	-	0.30
15.037.0	.3		20	10 24	15	37	30	4	-	-	-	0.30
15.051.0		03	20	10 39	15	51	44	4	-	-	-	0.35
22.025.4		04.3	30	17 15	22	25	19,4	4	-	-	-	0.20
22.038.0	.1	05.0	26	17 27	22	38	32.5	4	8	10	2	0.34
22.048.0	.1	06	30	17 36	22	48	41	4	13	10	2	0.37
22.060.5		07.5	26	16 48	22	60	53	4	9,5	10	2	0.54
30.030.3		1	40	24 18	30	30	23	4	-	-	-	0.50
30.060.3		2	40	24 48	30	60	53	4	-	-	-	0.60
30.050.0	.1	.5	10.0	10.5	35	23 34	30 50	40 5	9,5 5	5	3 <sup>2)</sup>	0.54
30.060.0	.1		11.0		35	23 44	30 60	50 5	9,5 5	5	3	0.61
30.080.0	.1 .2	.5	12.0	12.5	35	23 64	30 80	70 5	9,5 5	5	3 <sup>1),2)</sup>	0.65
30.095.0	.1		13.0		35	23 79	30 95	85 5	12 5	5	3	0.75
30.125.0	.1		14.0		35	23 109	30 125	115 5	12 5	5	3	0.87
40.062.2	.5		15.5		45	29 48	40 62	54 5	8 10	4	4	0.91
40.075.2	.6		45		45	29 60	40 75	67 5	8 10	4	4	1.05
50.065.0	.5	21.0	21.5		55	40 48	50 65	55 6	9 <sup>3)</sup>	9 <sup>3)</sup>	2	1.30
50.095.0	.1 .2	.5	19.0	19.5	55	40 78	50 95	85 6	6,5 <sup>3)</sup>	5 <sup>3)</sup>	2	1.35
50.125.0	.1		22.0		55	40 108	50 125	115 6	6,5	5	3	1.52
50.150.0	.1	.5	20.0	20.5	55	40 133	50 150	140 6	6,5 <sup>3)</sup>	5 <sup>3)</sup>	3	1.90
65.095.1	.5		24.5		70	50 77	65 95	85 6	13,5	10	4	2.20
65.135.1	.5		25.5		70	50 117	65 135	125 6	13,5	10	4	2.60
65.195.1			27.5		70	50 177	65 195	185 6	13,5	10	4	3,00

1) not Kolibri \*2

2) for Kolibri \*2 is t=4 for Kolibri \*5 is t=2

3) for Kolibri\*.5 is i=9,5 and j=10

# Kolibri DIMENSIONS

Kolibri 00.000.0

**standard type**

flap open bars in inner radius  
separable with pinch stay  
integrated connector



Kolibri 00.000.1

**openable in outer radius**

flap open bars in outer radius  
separable with pinch stay  
integrated connector



Kolibri 00.000.2

**rigid version**

flap open bars in inner radius  
separable with PZ  
integrated connector



Kolibri 00.000.6  
equal .2  
flap open bars  
in outer radius

Kolibri 00.000.3

**one part chain links**

not openable  
not separable  
integrated connector



Kolibri 00.000.4

**film stay**

film stay in inner radius  
not separable  
(integrated connector)



Kolibri 00.000.5

**closed type**

flap open stay covers in outer radius  
separable with pinch stay  
integrated connector



**Kolibri**

c . d . type	prev. name		radius								
10.012.4	00.3		15	30	50						
13.023.4			17,5	35							
15.015.3 .4	0	0.3	17,5 <sup>2)</sup>	20	30						
15.036.5		02.5		30	50						
15.037.3				24	30						
15.051.0	03			20	30						
22.025.4	04.3			35	70	100					
22.038.0 .1	05.0			35	50 <sup>6)</sup> 60 <sup>6)</sup> 70	100 <sup>6)</sup>					
22.048.0	06			35	70						
22.060.5		07.5			50	70	100				
30.030.3	1			40		100			200		
30.060.3	2			40		100	150	200			
30.050.0 .1 .5	10.0	10.5		40 <sup>1)</sup>	60	75	100	150	200		
30.060.0 .1	11.0			40	50	75	100	150	200		
30.080.0 .1 .2 .5	12.0	12.5		40 <sup>1)</sup>	60 <sup>4)</sup>	75	100	150	200		
30.095.0 .1	13.0			40		75	100	125	150	200	
30.125.0 .1	14.0			40		75	100	150	200		
40.062 .2 .5		15.5			60 <sup>1)</sup>	75	100	150	200		
40.075.2 .6					60	75	100	150	200		
50.065.0 .5	21.0	21.5			75 <sup>1)</sup>	100	125 <sup>1)</sup>	150	200	250	
50.095.0 .1 .2 .5	19.0	19.5			75 <sup>1)</sup>	100	125 <sup>1)</sup>	150	175 <sup>1)</sup>	200	250
50.125.0 .1	22.0				75	100 <sup>5)</sup>	125	150	200 <sup>5)</sup>	250 <sup>5)</sup>	
50.150.0 .1 .5	20.0	20.5			75 <sup>1)</sup>	100		150	200	250	
65.095.1 .5	24.1	24.5					125	150	200	300	
65.135.1 .5		25.5					125	150	200	300	400
65.195.1 .5		27.5					125	150	200	300	

1) not Kolibri xx.xxx.5

2) only Kolibri 15.015.3

4)only Kolibri 30.080.5

5) not 50.125.1

6) Nicht Verfügbar bei 22.038.1



# Kolibri SIZES

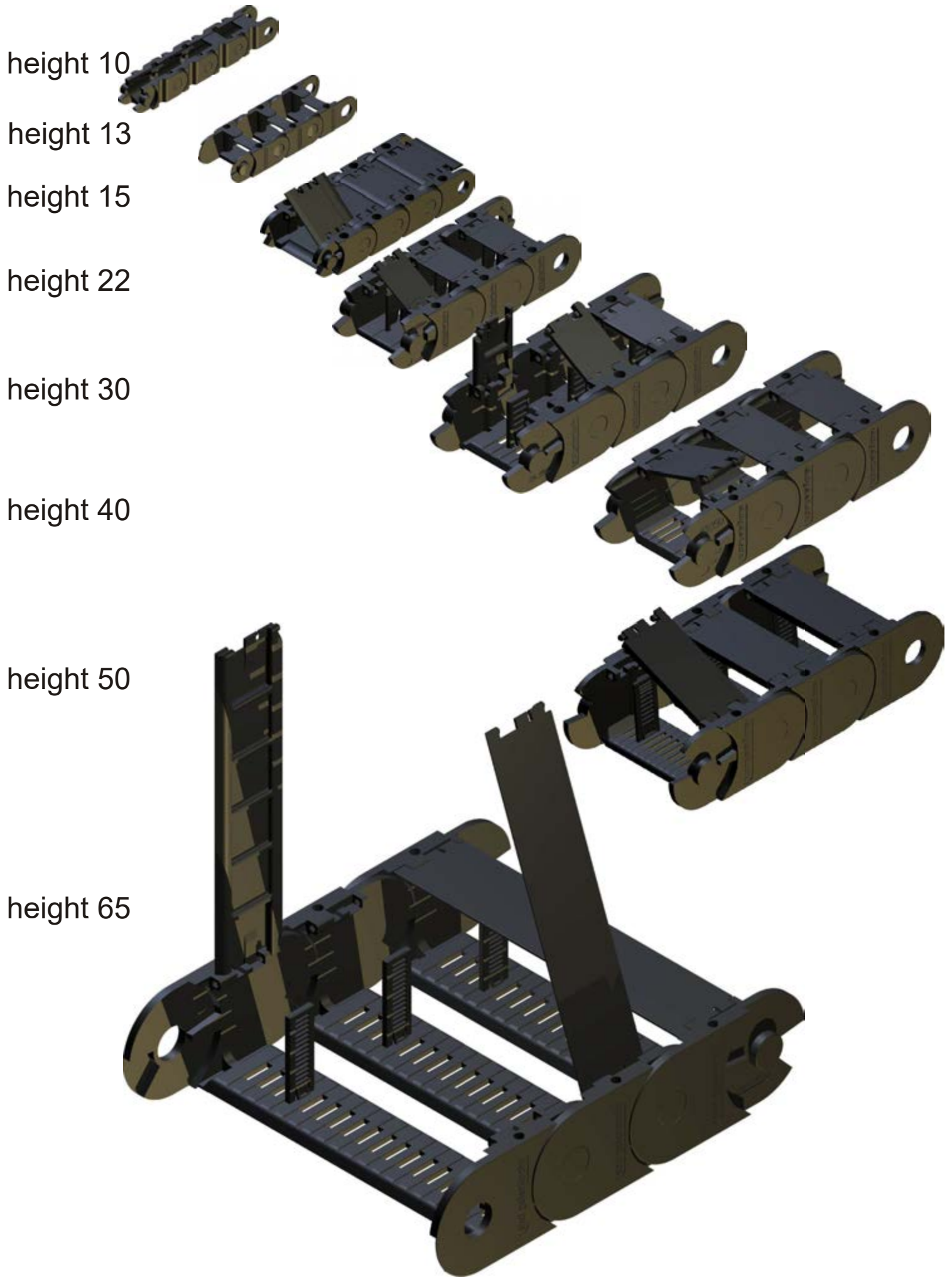

# Kolibri HEIGHT 10

inner height 7 up to 8, inner width 7 up to 14

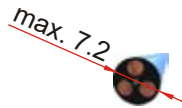

## Kolibri 10.012.4

one part link  
film stay in inner radius  
integrated connector or separate connectors  
**space (axb):**  $\varnothing 7$  not separable  
bend radius: 15 / 30 / 50  
weight: 0,05 kg/m  
free carrying length: 0.4 m at 0.3 kg/m load  
pitch: 15

order example:

**Kolibri 10.012.4 / 50 x 1005**

type / radius x length

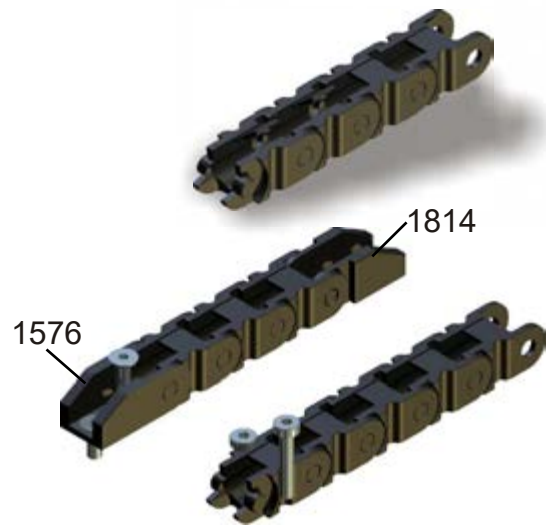

## Kolibri 13.023.4

one part link  
fether stay in inner radius  
integrated connector  
**space (axb):** 8x14 not separable  
bend radius: 17,5 / 35 / 55 / 80 / 100  
weight: 0,12 kg/m  
free carrying length: 0,8 m at 0.5 kg/m load  
pitch: 20

order example:

**Kolibri 10.012.4 / 50 x 1005**

type / radius x length

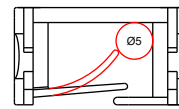

fether stay long  
max.  $\varnothing 5\text{mm}$

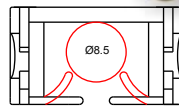

fether stay short  
Max.  $\varnothing 8.5\text{mm}$



max. 9



# Kolibri HEIGHT 15

inner height 10, inner width 10 to 39

## Kolibri 15.015.3

one part chain link  
 not openable  
 connector as separate part (part.no. 0700)  
**space (axb):**             $\varnothing 10$     not separable  
 bend radius:            17.5 / 20 / 30  
 weight:                    0.15    kg/m  
 free carrying length:   0,9m    at 0.9 kg/m load  
 pitch:                     20

order example:

**Kolibri 15.015.3 / 30 x 1000**

type / radius x length



## Kolibri 15.015.4

one part chain link  
 film-stay in inner radius  
 connector as separate part (see Kolibri 15.015.3)  
**space (axb):**             $\varnothing 10$     not separable  
 bend radius:            20 / 30  
 weight:                    0.15    kg/m  
 free carrying length:   0.9 m    at 0.9 kg/m load  
 pitch:                     20

order example:

**Kolibri 15.015.4 / 30 x 1000**

type / radius x length

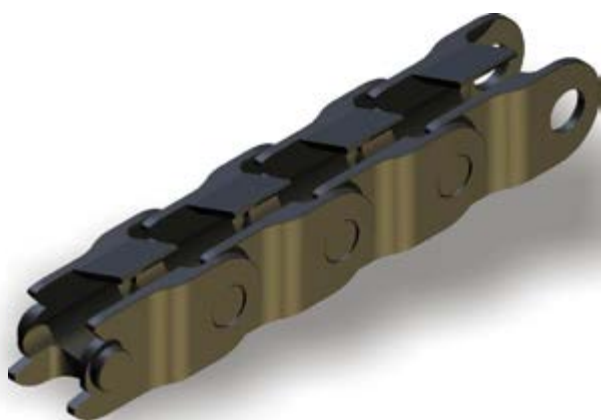

## Kolibri 15.036.5

closed type  
 flap covers in outer radius  
 integrated connectors  
**space (axb):**            10 x 25 not separable  
 bend radius:            30 / 50  
 weight:                    0.3    kg/m  
 free carrying length:   0.9m    at 0.9 kg/m load  
 pitch:                     18

order example:

**Kolibri 15.036.5 / 30 x 1008**

type / radius x length





# Kolibri HEIGHT 15

inner height 10, inner width 10 to 39

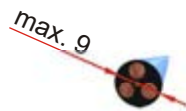

## Kolibri 15.037.3

one part chain link  
not openable, closed in outer radius  
integrated connectors

**Space (axb):** 10 x 24 not separable  
**bend radius:** 24, 30  
**weight:** 0.3 kg/m  
**free carrying length:** 0.9 at 0.9 kg/m load  
**pitch:** 20

order example:

**Kolibri 15.037.3 / 30 x 1000**

type / radius x length



## Kolibri 15.051.0

standard type  
flap stay in inner radius  
integrated connectors

**space (axb):** 10 x 39 not separable  
**bend radius:** 20 / 30  
**weight:** 0.35 kg/m  
**free carrying length:** 0.9 m at 0.9 kg/m load  
**pitch:** 20

order example:

**Kolibri 15.051.0 / 30 x 1000**

type / radius x length

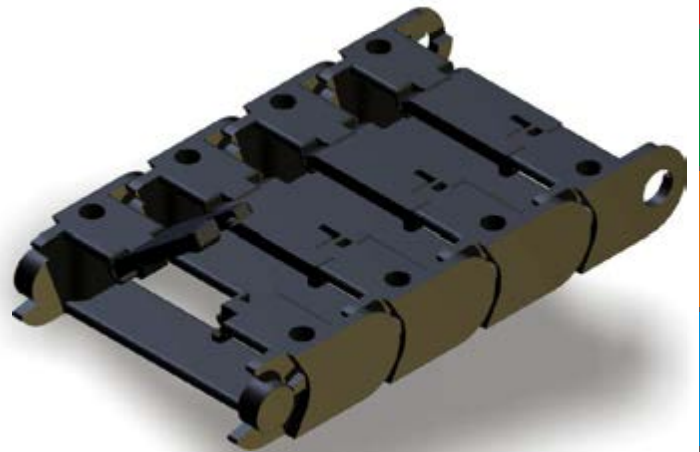

max. 14-20



# Kolibri HEIGHT 22

inner height 16 to 22, inner width 15 to 48



## Kolibri 22.025.4

one part chain link  
film stay  
integrated connectors

space (axb): 17 x 15 not separable  
bend radius: 35 / 70 / 100  
weight: 0.20 kg/m  
free carrying length: 1.3 m at 1.5 kg/m load  
pitch: 30

order example:

**Kolibri 22.025.4 / 35 x 1020**

type / radius x length

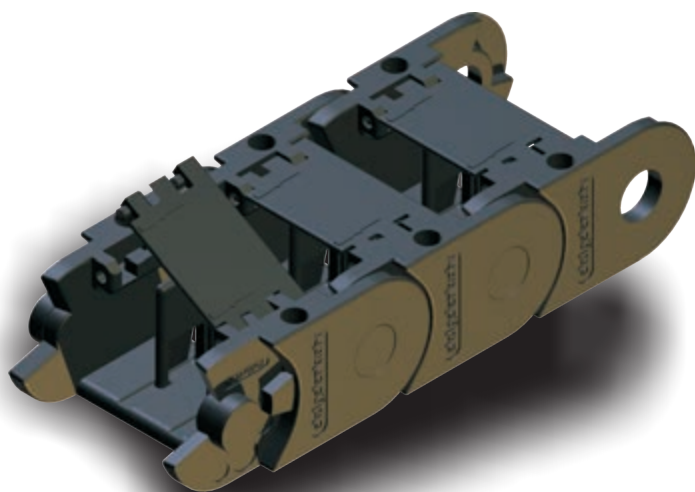

## Kolibri 22.038.0

standard type  
flap stay in inner radius  
integrated connectors

space (axb): 17 x 27 separable (PZ ANr.1688)  
bend radius: 35 / 50 / 60 / 70 / 100  
weight: 0.34 kg/m  
free carrying length: 1.5 m at 1.0 kg/m load  
pitch: 26

order example:

**Kolibri 22.038.0 / 35 x 1040**

type / radius x length



## Kolibri 22.038.1

open type  
flap stay in outer radius  
integrated connectors

space (axb): 17 x 27 separable (PZ ANr.1688)  
bend radius: 35 / 70  
weight: 0.34 kg/m  
free carrying length: 1.5 m at 1.0 kg/m load  
pitch: 26

order example:

**Kolibri 22.038.1 / 35 x 1040**

type / radius x length

# Kolibri HEIGHT 22

inner height 16 to 22, inner width 15 to 48

## Kolibri 22.048.0

open type  
flap stay in inner radius  
integrated connectors

space (axb): 17 x 36 not separable  
bend radius: 35 / 70  
weight: 0.37 kg/m  
free carrying length: 1.3 m at 1.5 kg/m load  
pitch: 30

order example:

**Kolibri 22.048.0 / 35 x 1200**

type / radius x length

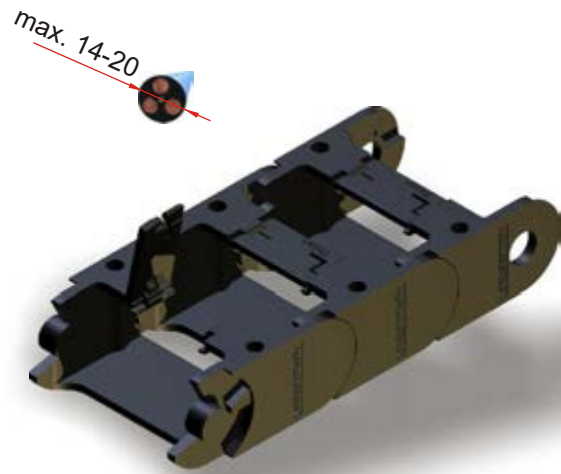

## Kolibri 22.060.5

closed type  
flap stay in outer radius  
integrated connectors

space (axb): 16 x 48 separable (PZ ANr.1294)  
bend radius: 50 / 70 / 100  
weight: 0.54 kg/m  
free carrying length: 1.3 m at 1.5 kg/m load  
pitch: 26

order example:

**Kolibri 22.060.5 / 100 x 1014**

type / radius x length





max. 21



## Kolibri HEIGHT 30

inner height 23 to 24, inner width 18 to 109

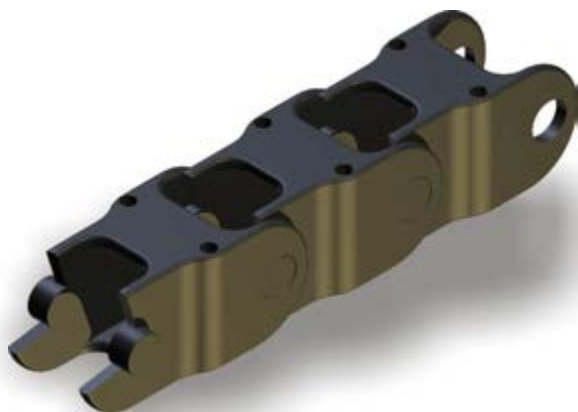

### Kolibri 30.030.3

one part chain link  
not openable  
integrated connectors

space (axb): **24 x 18 not separable**  
bend radius: 40 / 100 / 200  
weight: 0.50 kg/m  
free carrying length: 1.5 m at 2.0 kg/m load  
pitch: 40

order example:

**Kolibri 30.030.0 / 100 x 1200**

type / radius x length

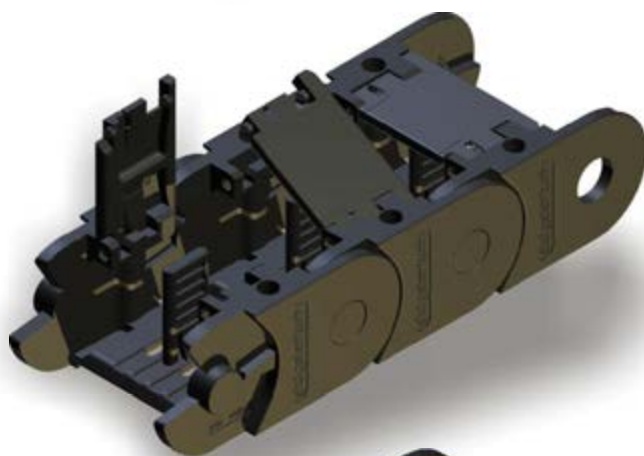

### Kolibri 30.050.0

standard type  
flap stay in inner radius  
integrated connectors

space (axb): **23 x 34 separable (PZ ANr.1258)**  
bend radius: 40 / 60 / 75 / 100 / 150 / 200  
weight: 0.54 kg/m  
free carrying length: 1.5 m at 2.0 kg/m load  
pitch: 35

order example:

**Kolibri 30.050.0 / 100 x 1225**

type / radius x length

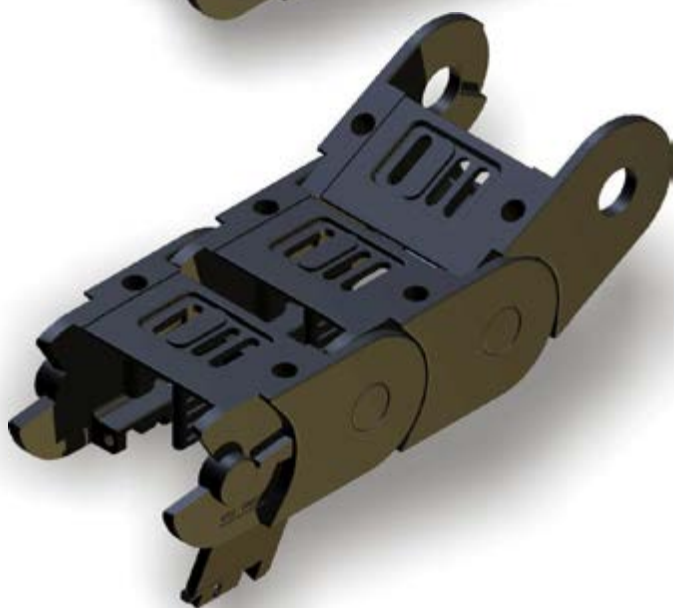

### Kolibri 30.050.1

open type  
flap stay in outer radius  
integrated connectors

space (axb): **23 x 34 separable (PZ ANr.1258)**  
bend radius: 40 / 60 / 75 / 100 / 150 / 200  
weight: 0.54 kg/m  
free carrying length: 1.5 m at 2.0 kg/m load  
pitch: 35

order example:

**Kolibri 30.050.1 / 100 x 1225**

type / radius x length

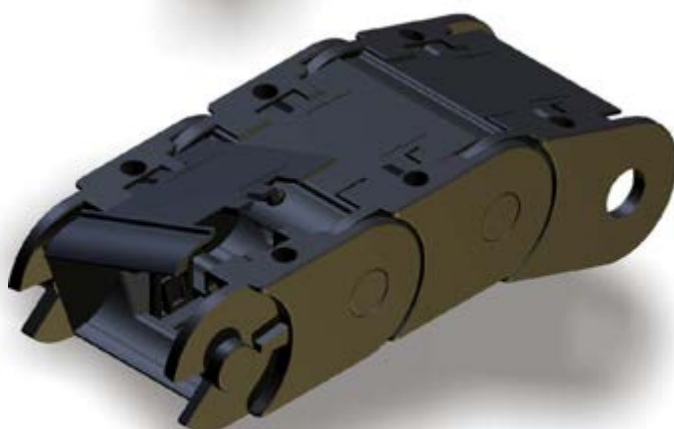

### Kolibri 30.050.5

closed type  
flap covers in outer radius  
integrated connectors

space (axb): **23 x 34 separable (PZ ANr.1017)**  
bend radius: 60 / 75 / 100 / 150 / 200  
weight: 0.58 kg/m  
free carrying length: 1.5 m at 2.0 kg/m load  
pitch: 35

order example:

**Kolibri 30.050.5 / 100 x 1225**

type / radius x length

# Kolibri HEIGHT 30

inner height 23 to 24, inner width 18 to 109

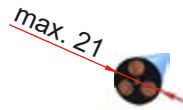

## Kolibri 30.060.0

standard type  
flap stay in inner radius  
integrated connectors

space (axb): 23 x 44 separable (PZ ANr.1258)  
bend radius: 40 / 50 / 75 / 100 / 150 / 200  
weight: 0.61 kg/m  
free carrying length: 1.5 m at 2.0 kg/m load  
pitch: 35

order example:

**Kolibri 30.060.0 / 100 x 1225**

type / radius x length

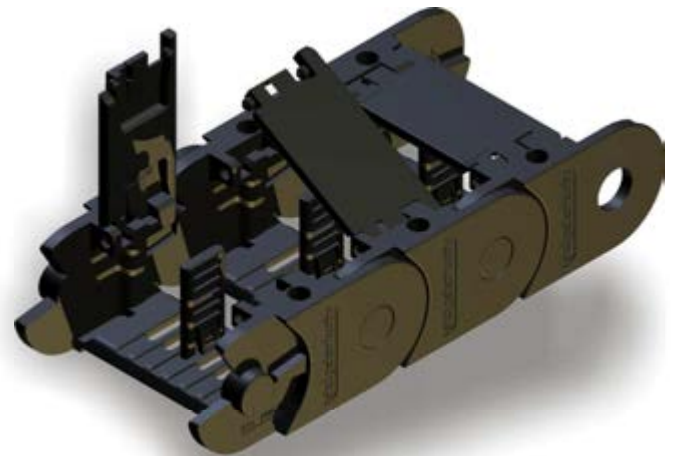

## Kolibri 30.060.1

open type  
flap stay in outer radius  
integrated connectors

space (axb): 23 x 44 separable (PZ ANr.1258)  
bend radius: 40 / 50 / 75 / 100 / 150 / 200  
weight: 0.61 kg/m  
free carrying length: 1.5 m at 2.0 kg/m load  
pitch: 35

order example:

**Kolibri 30.060.1 / 100 x 1225**

type / radius x length

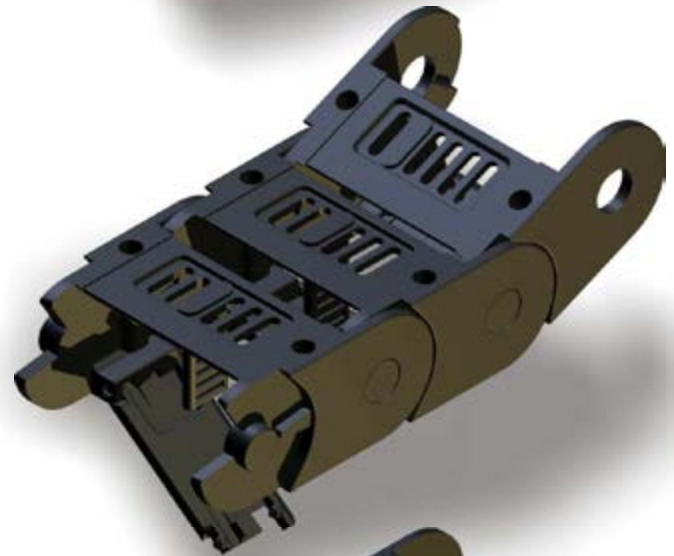

## Kolibri 30.060.3

open type  
not openable  
integrated connectors

space (axb): 24 x 48  
bend radius: 40 / 100 / 150 / 200  
weight: 0.60 kg/m  
free carrying length: 1.5 m at 2.0 kg/m load  
pitch: 40

order example:

**Kolibri 30.060.3 / 100 x 1200**

type / radius x length

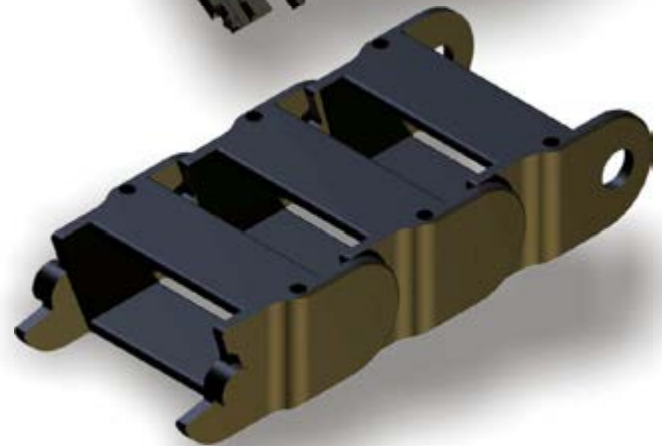

## Kolibri 30.080.0

standard type  
flap stay in inner radius  
integrated connectors

space (axb): 23 x 64 separable (PZ ANr.1258)  
bend radius: 40 / 75 / 100 / 150 / 200  
weight: 0.65 kg/m  
free carrying length: 1.5 m at 2.0 kg/m load  
pitch: 35

order example:

**Kolibri 30.080.0 / 100 x 1225**

type / radius x length

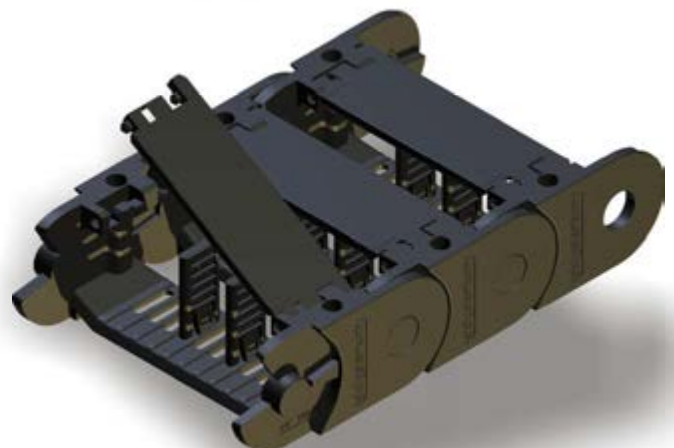

# Kolibri HEIGHT 30

inner height 23 to 24, inner width 18 to 109

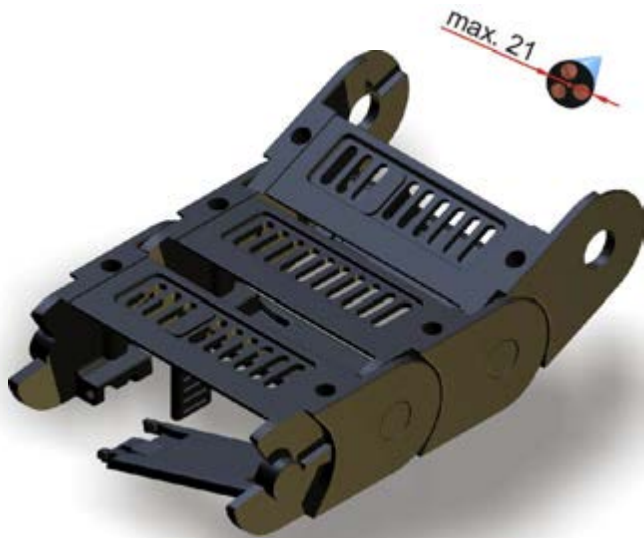

## Kolibri 30.080.1

standard type  
flap stay in outer radius  
integrated connectors

space (axb): 23 x 64 separable (PZ ANr.1258)  
bend radius: 40 / 75 / 100 / 150 / 200  
weight: 0.65 kg/m  
free carrying length: 1.5 m at 2.0 kg/m load  
pitch: 35

order example:

**Kolibri 30.080.0 / 100 x 1225**

type / radius x length

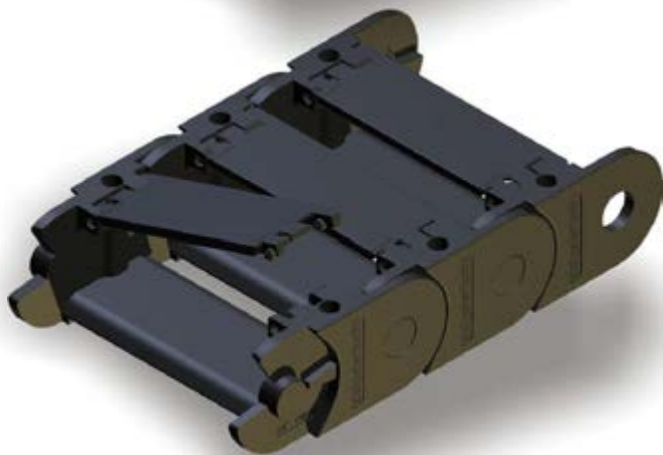

## Kolibri 30.080.2

rigid type  
flap stay in inner radius  
integrated connectors

space (axb): 21 x 64 not separable  
bend radius: 40 / 75 / 100 / 150 / 200  
weight: 0.7 kg/m  
free carrying length: 1.5 m at 2.0 kg/m load  
pitch: 35

order example:

**Kolibri 30.080.2 / 100 x 1225**

type / radius x length



## Kolibri 30.080.5

closed type  
flap covers in outer radius  
integrated connectors

space (axb): 23 x 64 separable (PZ ANr.1017)  
bend radius: 60 / 75 / 100 / 150 / 200  
weight: 0.7 kg/m  
free carrying length: 1.5 m at 2.0 kg/m load  
pitch: 35

order example:

**Kolibri 30.080.5 / 100 x 1225**

type / radius x length



# Kolibri HEIGHT 30

inner height 23 to 24, inner width 18 to 109

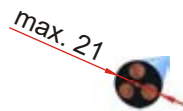

## Kolibri 30.095.0

standard type  
flap stays in inner radius  
integrated connectors

space (axb): 23 x 79 separable (PZ ANr.1258)  
bend radius: 40 / 75 / 100 / 125 / 150 / 200  
weight: 0.75 kg/m  
free carrying length: 1.5 m at 2.0 kg/m load  
pitch: 35

order example:

**Kolibri 30.095.0 / 100 x 1225**

type / radius x length

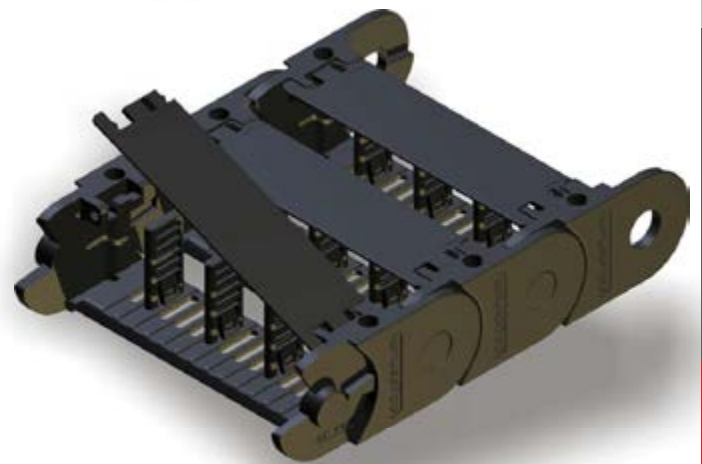

## Kolibri 30.095.1

open type  
flap stays in outer radius  
integrated connectors

space (axb): 23 x 79 separable (PZ ANr.1258)  
bend radius: 40 / 75 / 100 / 125 / 150 / 200  
weight: 0.75 kg/m  
free carrying length: 1.5 m at 2.0 kg/m load  
pitch: 35

order example:

**Kolibri 30.095.1 / 100 x 1225**

type / radius x length

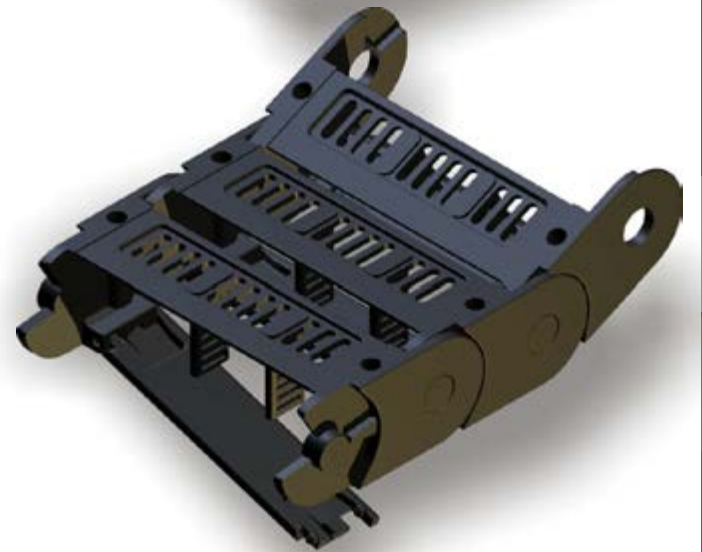

max. 21 

## Kolibri HEIGHT 30

inner height 23 to 24, inner width 18 to 109

### Kolibri 30.125.0

standard type  
flap stay in inner radius  
integrated connectors

space (axb): 23 x 109 separable (PZ ANr.1258)  
bend radius: 40 / 75 / 100 / 150 / 200  
weight: 0.87 kg/m  
free carrying: 1.5 m at 2.0 kg/m load  
pitch: 35

order example:

**Kolibri 30.125.0 / 100 x 1225**

type / radius x length

### Kolibri 30.125.1

open type  
flap stay in outer radius  
integrated connectors

space (axb): 23 x 109 separable (PZ ANr.1258)  
bend radius: 40 / 75 / 100 / 150 / 200  
weight: 0.87 kg/m  
free carrying: 1.5 m at 2.0 kg/m load  
pitch: 35

order example:

**Kolibri 30.125.1 / 100 x 1225**

type / radius x length

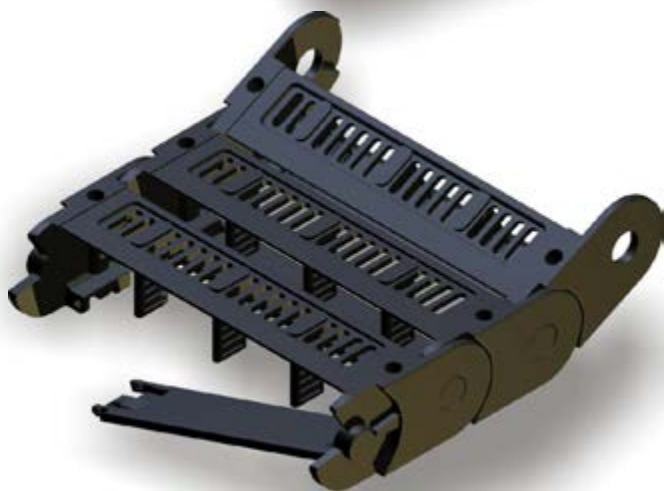
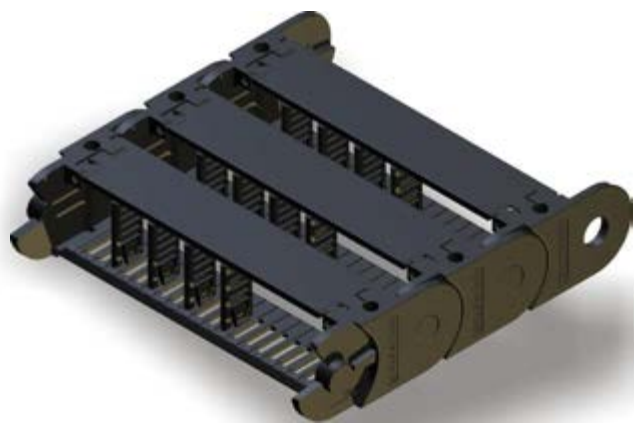

# Kolibri HEIGHT 40

inner height 31, inner width 48 to 60

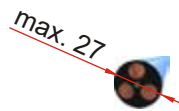

## Kolibri 40.062.2

rigid type  
flap stay in inner radius  
integrated connectors

space (axb): 29 x 48 separable ((PZ ANr.1521))  
bend radius: 60 / 75 / 100 / 150 / 200  
weight: 0.91 kg/m  
free carrying length: 2.0 m at 1.0 kg/m load  
pitch: 45

order example:

Kolibri 40.062.2 / 100 x 1260

type / radius x length

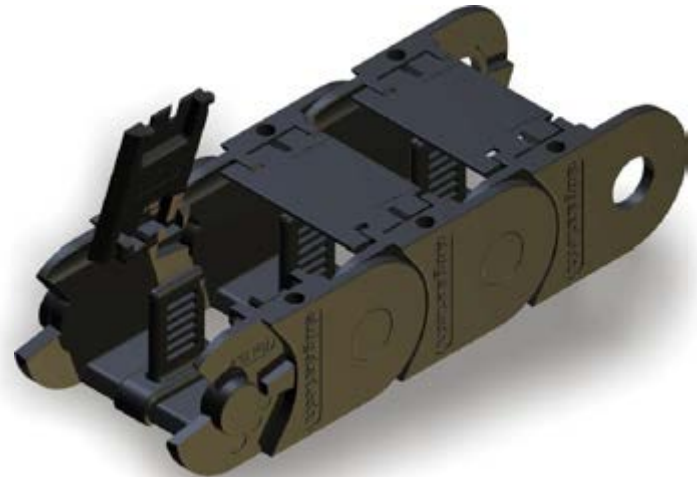

## Kolibri 40.062.5

closed type  
flap covers in outer radius  
integrated connectors

space (axb): 29 x 48 separable ((PZ ANr.1268))  
bend radius: 75 / 100 / 150 / 200  
weight: 0.93 kg/m  
free carrying length: 2.0 m at 1.0 kg/m load  
pitch: 45

order example:

Kolibri 40.062.5 / 100 x 1260

type / radius x length

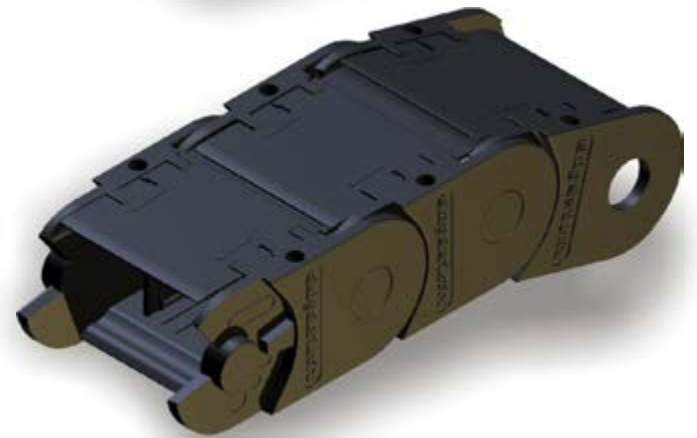



## Kolibri HEIGHT 40

inner height 31, inner width 48 to 60

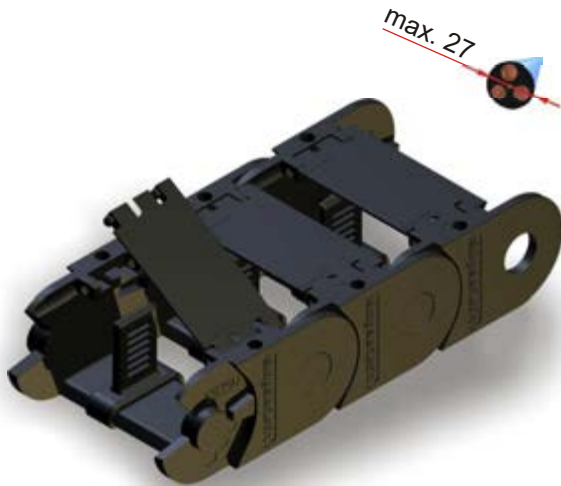

### Kolibri 40.075.2

rigid type

flap stay in inner radius

integrated connectors

space (axb): 29 x 60 separable (PZ ANr.1521)

bend radius: 60 / 75 / 100 / 150 / 200

weight: 1.05 kg/m

free carrying length: 2.0 m at 1.0 kg/m load

pitch: 45

order example:

**Kolibri 40.075.2 / 100 x 1260**

type / radius x length

### Kolibri 40.075.6

rigid type

flap stay in outer radius

integrated connectors

space (axb): 29 x 60 separable (PZ ANr.1521)

bend radius: 60 / 75 / 100 / 150 / 200

weight: 1.05 kg/m

free carrying length: 2.0 m at 1.0 kg/m load

pitch: 45

order example:

**Kolibri 40.075.6 / 100 x 1260**

type / radius x length

# Kolibri HEIGHT 50

inner height 38 to 40, inner width 48 to 134



## Kolibri 50.065.0

standard type  
flap stay in inner radius  
integrated connectors

space (axb): 40 x 48 separable (PZ ANr.1113)  
bend radius: 75 / 100 / 125 / 150 / 200 / 250  
weight: 1.30 kg/m  
free carrying: 2.4 m at 1.0 kg/m load  
pitch: 55

order example:

**Kolibri 50.065.0 / 100 x 1265**

type / radius x length



## Kolibri 50.065.5

colsed type  
flap covers in outer radius  
integrated connectors

space (axb): 40 x 48 separable (PZ ANr.1113)  
bend radius: 100 / 150 / 200 / 250  
weight: 1.30 kg/m  
free carrying length: 2.4 m at 1.0 kg/m load  
pitch: 55

order example:

**Kolibri 50.065.5 / 100 x 1265**

type / radius x length

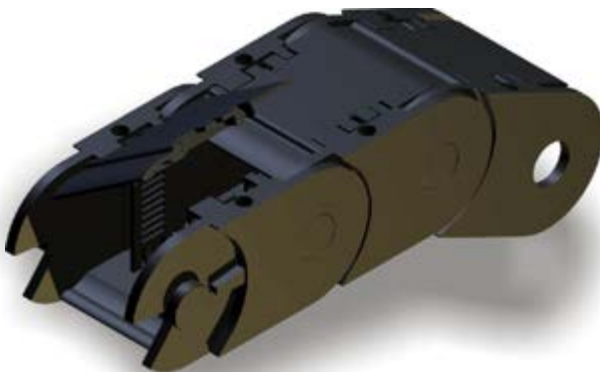

## Kolibri 50.095.0 50.095.1

standard type  
flap stay in inner radius    flap stay in outer radius  
integrated connectors

space (axb): 40 x 78 separable (PZ ANr.1113)  
bend radius: 75/100/ 125/ 150/ 175/ 200/ 250  
weight: 1.35 kg/m  
free carrying length: 2.4 m at 1.0 kg/m load  
pitch: 55

order example:

**Kolibri 50.095.0 / 100 x 1265**

type / radius x length

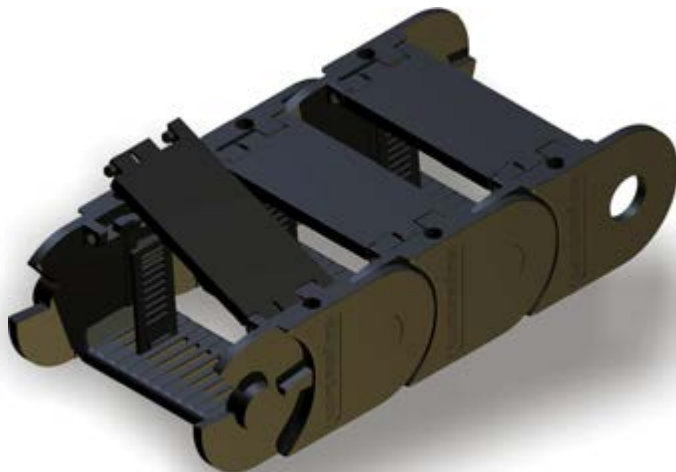

## Kolibri 50.095.2

rigid type  
flap stay in inner radius  
integrated connectors

space (axb): 38 x 78 separable (PZ ANr.1451)  
bend radius: 75/100/ 125/ 150/ 175/ 200/ 250  
weight: 1.40 kg/m  
free carrying length: 2.4 m at 1.0 kg/m load  
pitch: 55

order example:

**Kolibri 50.095.2 / 100 x 1265**

type / radius x length

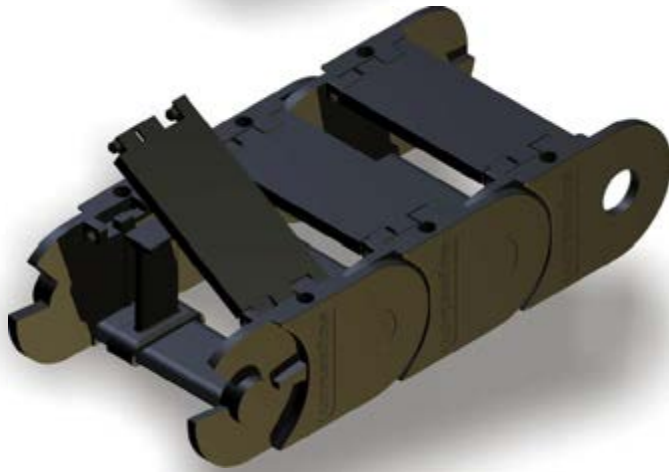

max. 36



# Kolibri HEIGHT 50

inner height 38 to 40, inner width 48 to 134

## Kolibri 50.095.5

closed type  
flap stay in outer radius  
integrated connectors

space (axb): 40 x 78 separable (PZ ANr.1113)  
bend radius: 100/ 125/ 150/ 175/ 200/ 250  
weight: 1.40 kg/m  
free carrying length: 2.4 m at 1.0 kg/m load  
pitch: 55

order example:

**Kolibri 50.095.5 / 100 x 1265**

type / radius x length

## Kolibri 50.125.0 50.125.1

standard type  
flap stay in inner radius  
Integrated connectors

flap stay in outer radius

space (axb): 40 x 108 separable (PZ ANr.1326)  
bend radius: 75 / 100 / 125 / 150 / 200 / 250  
weight: 1.52 kg/m  
free carrying length: 2.4 m at 1.0 kg/m load  
pitch: 55

order example:

**Kolibri 50.125.0 / 100 x 1265**

type / radius x length

## Kolibri 50.150.0 50.150.1

standard type  
flap stay in inner radius  
integrated connectors

flap stay in outer radius

space (axb): 40 x 133 separable (PZ ANr.1326)  
bend radius: 75 / 100 / 150 / 200 / 250  
weight: 1.90 kg/m  
free carrying length: 2.4 m at 1.0 kg/m load  
pitch: 55

order example:

**Kolibri 50.150.0 / 100 x 1265**

type / radius x length

## Kolibri 50.150.5

closed type  
flap stay in outer radius  
integrated connectors

space (axb): 40 x 133 separable (PZ ANr.1113)  
bend radius: 75 / 100 / 150 / 200 / 250  
weight: 1.90 kg/m  
free carrying length: 2.4 m at 1.0 kg/m load  
pitch: 55

order example:

**Kolibri 50.150.5 / 100 x 1265**

type / radius x length

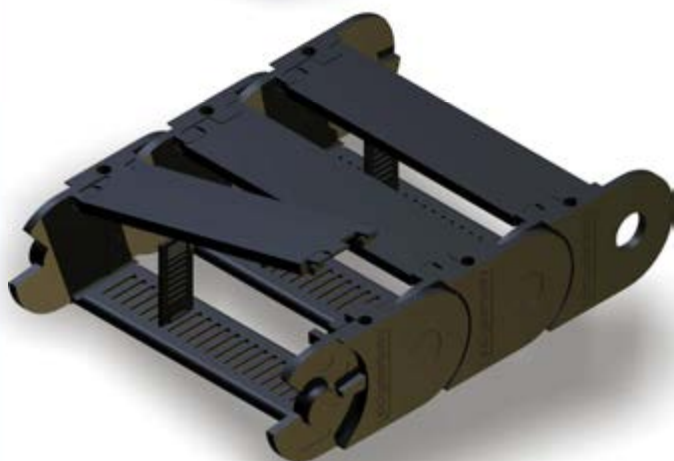
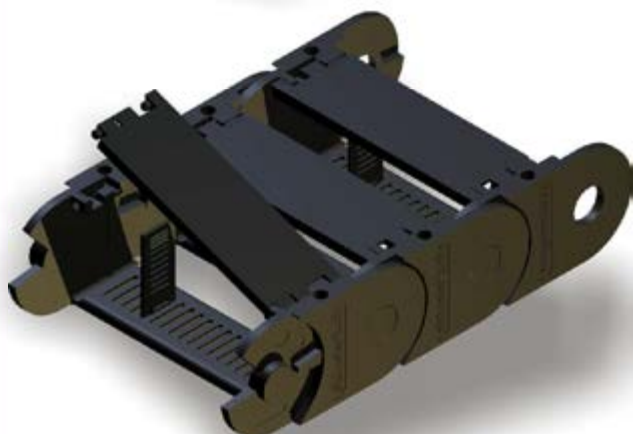
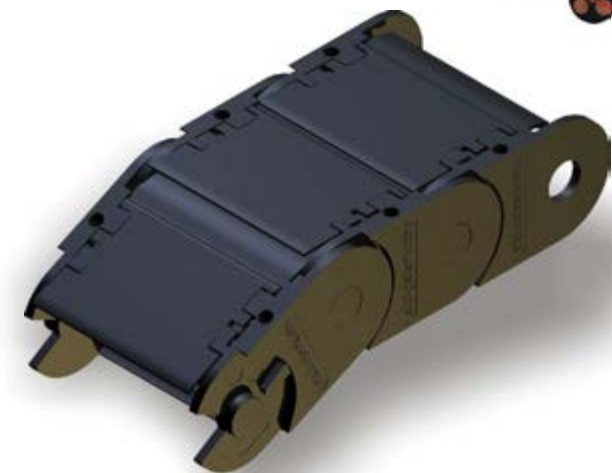



# Kolibri HEIGHT 65

inner height 50, inner width 77 to 205

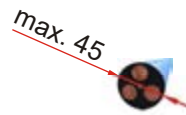

## Kolibri 65.095.1

open type  
flap stay in outer radius  
integrated connectors

space (axb): 50 x 77 separable (PZ ANr.1129)  
bend radius: 125 / 150 / 200 / 300  
weight: 2.2 kg/m  
free carrying length: 2.75 m at 1.0 kg/m load  
pitch: 70

order example:

**Kolibri 65.095.1 / 125 x 1400**

type / radius x length



## Kolibri 65.095.5

closed type  
flap cover in outer radius  
integrated connectors

space (axb): 50 x 77 separable (PZ ANr.1129)  
bend radius: 125 / 150 / 200 / 300  
weight: 2.2 kg/m  
free carrying length: 2.75 m at 1.0 kg/m load  
pitch: 70

order example:

**Kolibri 65.095.5 / 125 x 1400**

type / radius x length



## Kolibri 65.135.1

open type  
flap stay in outer radius  
integrated connectors

space (axb): 50 x 117 separable (PZ ANr.1129)  
bend radius: 125 / 150 / 200 / 300 / 400  
weight: 2.6 kg/m  
free carrying length: 2.75 m at 1.0 kg/m load  
pitch: 70

order example:

**Kolibri 65.135.1 / 125 x 1400**

type / radius x length

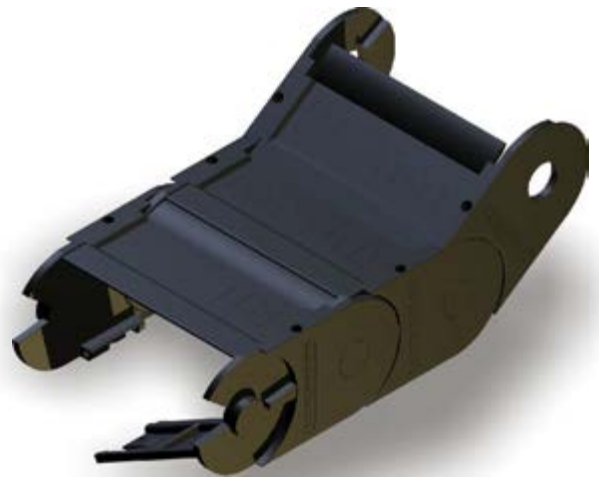

## Kolibri 65.135.5

closed type  
flap cover in outer radius  
integrated connectors

space (axb): 50 x 117 separable (PZ ANr.1129)  
bend radius: 125 / 150 / 200 / 300 / 400  
weight: 2.7 kg/m  
free carrying length: 2.75 m at 1.0 kg/m load  
pitch: 70

order example:

**Kolibri 65.135.1 / 125 x 1400**

type / radius x length



max. 45



## Kolibri HEIGHT 65

inner height 50, inner width 77 to 205



### Kolibri 65.195.1

open type  
flap stay in outer radius  
integrated connectors

space (axb): 50 x 177 separable (PZ ANr.1129)  
bend radius: 125 / 150 / 200 / 300  
weight: 2.9 kg/m  
free carrying length: 2.75 m at 1.0 kg/m load  
pitch: 70

order example:

Kolibri 65.195.1 / 125 x 1400

type / radius x length



### Kolibri 65.195.5

closed type  
flap cover in outer radius  
integrated connectors

space (axb): 50 x 177 separable (PZ ANr.1129)  
bend radius: 125 / 150 / 200 / 300  
weight: 3.0 kg/m  
free carrying length: 2.75 m at 1.0 kg/m load  
pitch: 70

order example:

Kolibri 65.195.5 / 125 x 1400

type / radius x length

# Kolibri PARTS

Pos.	name
1	link (open type)
2	link (closed type)
3	flange pivot
4	flange drilling
5	horn stay connector
6	horn stay 65 HS65
7	horn stay 85 HS 85
8	damping element
9	PZ (divider)
10	PZ (pinch stay)
11	flap stay
12	flap cover
13	notched horizontal divider
14	notched horiz. divider flying
15	telescopic horizontal divider
16	telescopic horiz. divider flying
17	ladderstay
20	connector 10.012.4 hole
21	connector 10.012.4 pivot

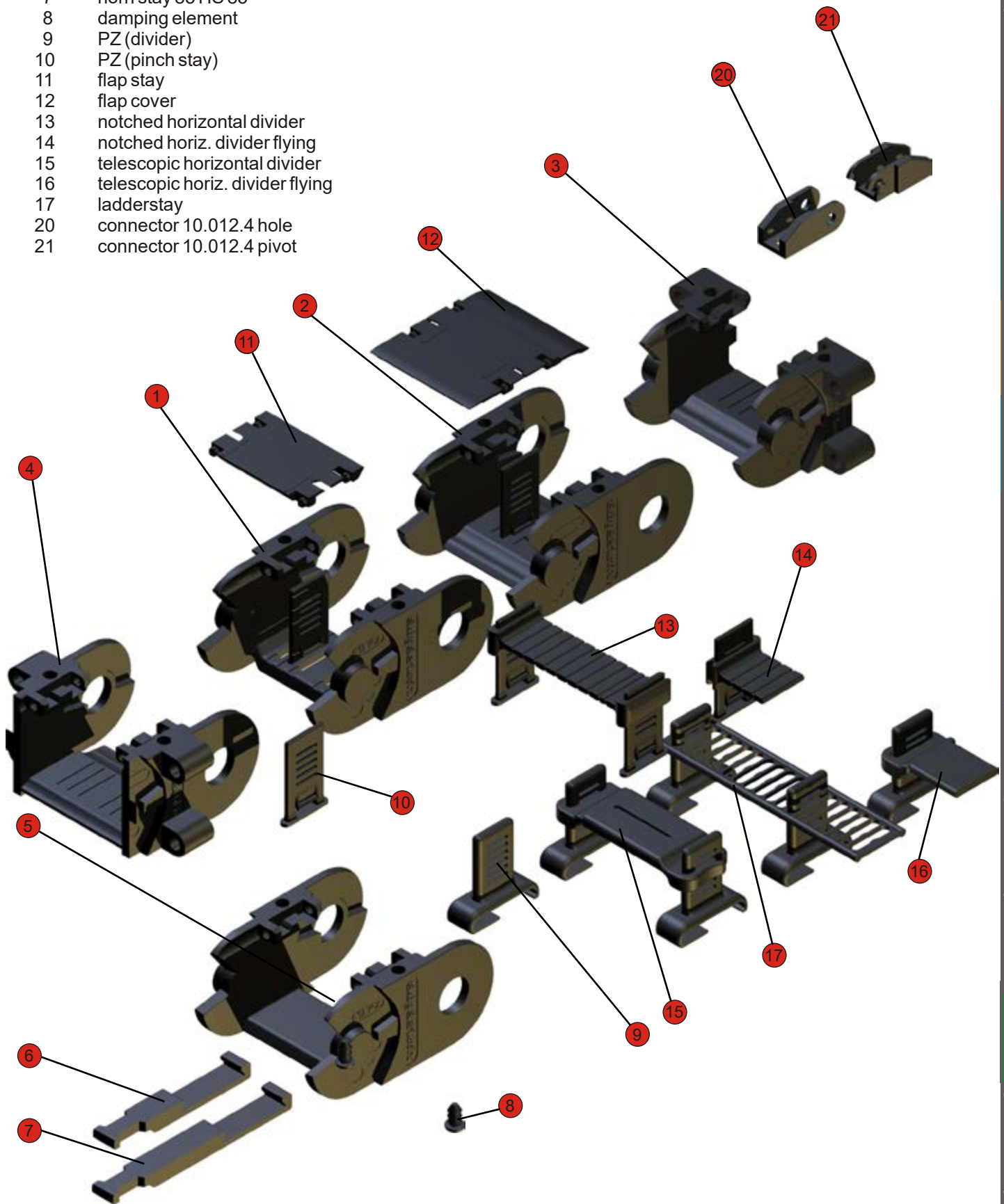



## Opening and closing

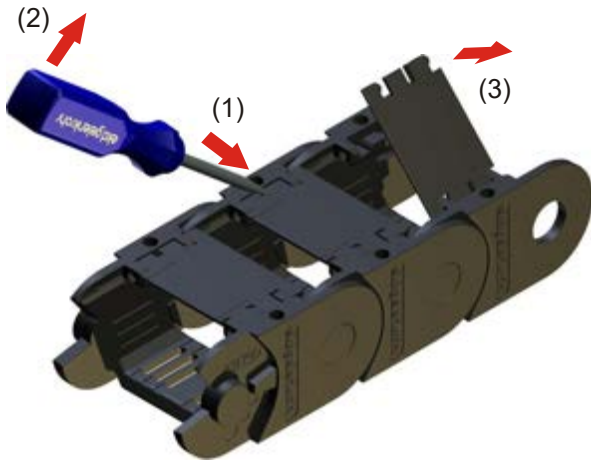

Push a screwdriver as shown in the the slot (1) then with a light lever movement (2) raise the tongue and push the locking pins of the flap stay (or the flap cover) out of the drilling. The flap stay can then be lifted (3). To remove the flap stay the second side has to be unlocked and the stay has to be pushed out against the direction of the cones.

The installation of the flap stays and flap covers are snapped in a slight angle with the pins against the corresponding drillings (4) and with slight pressure against the locking tongue.

Lifted flap stays can be re-engaged (5) with slight pressure.

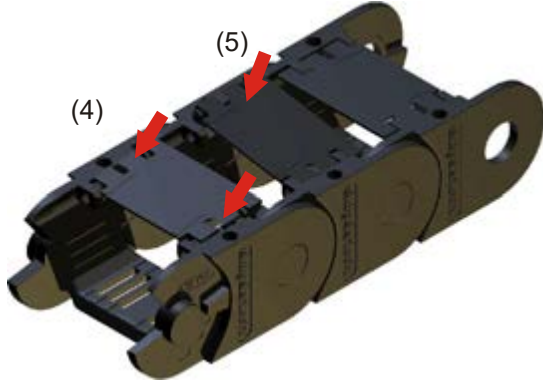

## Lengthening and shortening

To lengthen or shorten the flap stays have to be opened. The walls with pivot pins are to press internally (1) and the walls with the holes are to press toward the outside (2). The chain links can be pushed together (3), or be pulled apart.

## Installation of the flap stays

The assembly of the flap stays can take place before or after cable lining. Therefore energy chain does not need to be opened. The flap stays are inserted from the outside chain link floor until snap (1), (2). The dismantling of the stays is done by unlocking the tongue and pushing out (3).

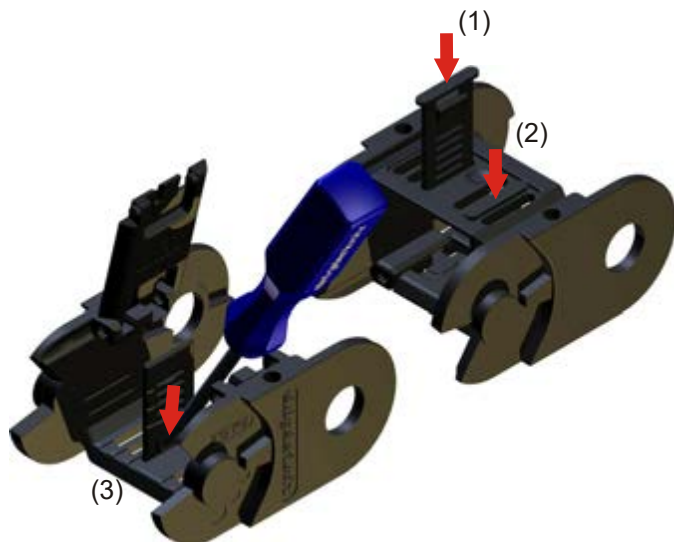
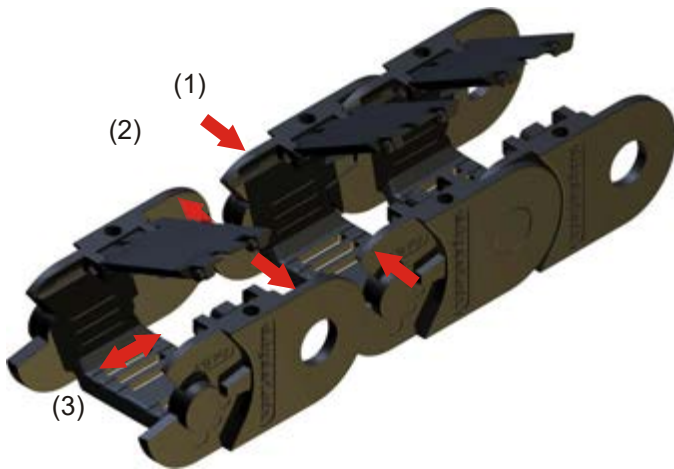

## Assembly of horizontal dividers

The horizontal dividers (notched, telescopic and ladder-stay) are horizontally slid onto the vertical dividers (PZ) (1).

With a screwdriver the locking tongue can be mounted (2) and horizontal dividers disassembled (3).

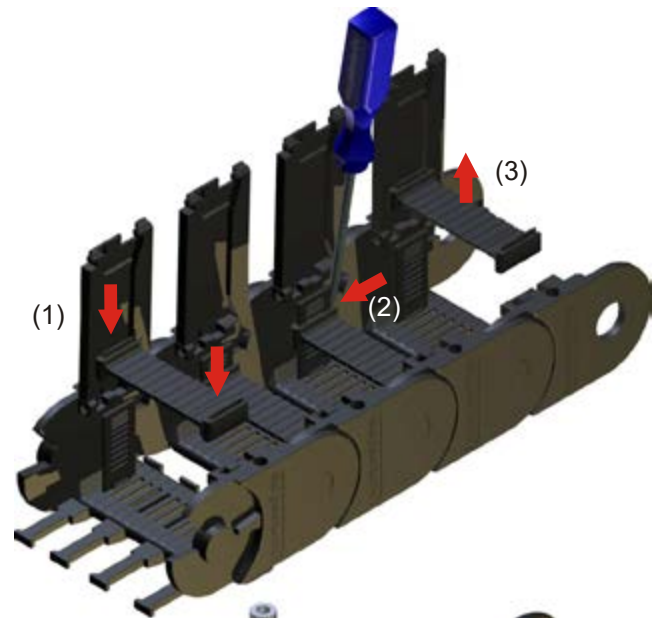

## Mounting the energy chain and strain relief

Before mounting the energy chain horn stays may be assembled which can be used to fix the lines via cable ties. For most applications variable strain relief is recommended, to mount the anchor profile with the energy chain using the integrated connector. (1), (2).

It is also possible to attach the anchor profile as a separate strain relief. The anchor profile is suitable for various strain relief components (see design guidelines).

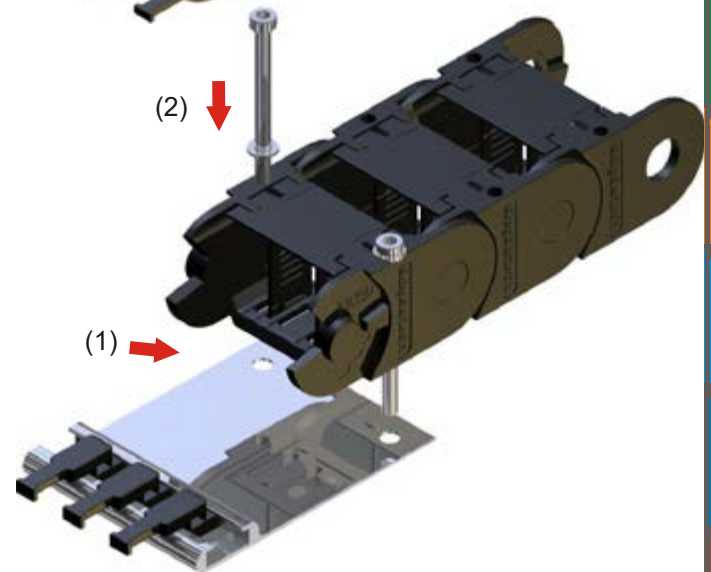

Alternatively, it is possible to mount the cable chains with flush mounting flange type brackets (1).

## Maintenance of the energy chain

Kolibri energy chains are maintenance free. Like every mechanical system there will - depending on the ambient conditions - wear which must be observed.

In case of this the energy chainspace has to be exchanged.

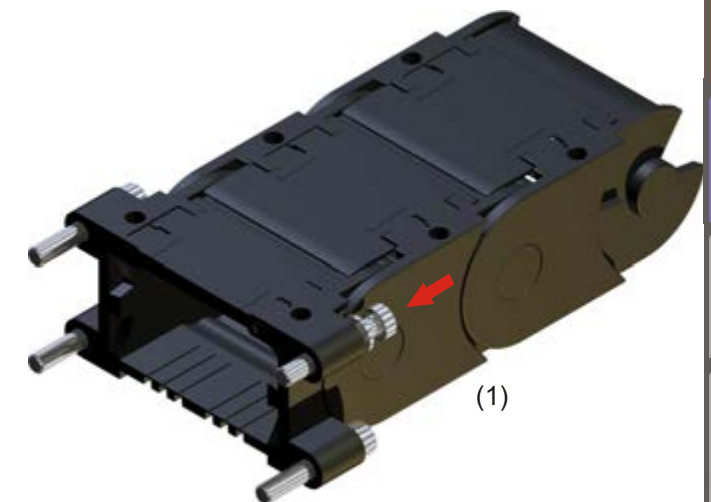

# Kolibri MOUNTING BRACKETS

Kolibri 15.036.5  
(Kolibri 02.5)

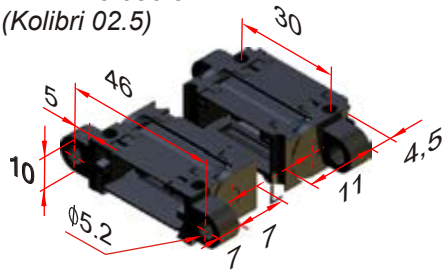

Kolibri 22.038.0  
(Kolibri 05.0)

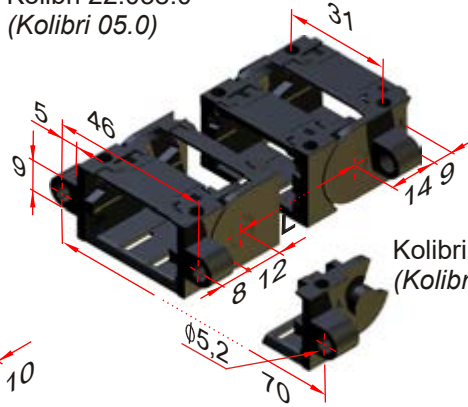

Kolibri 30.050.0  
(Kolibri 10.0)

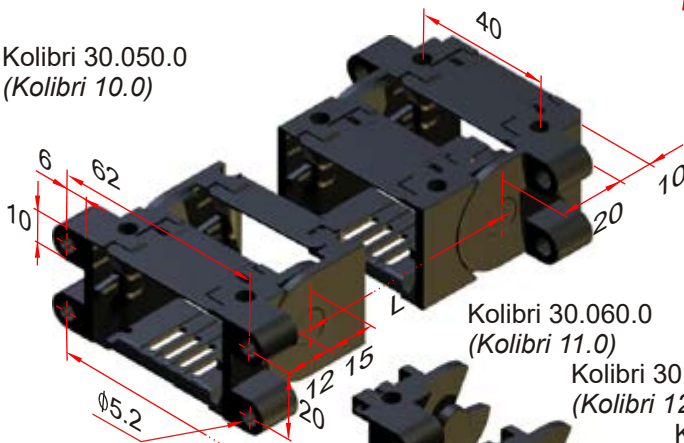

Kolibri 22.060.5  
(Kolibri 07.5)

Kolibri 30.060.0  
(Kolibri 11.0)

Kolibri 30.080.0  
(Kolibri 12.0)

Kolibri 30.095.0  
(Kolibri 13.0)

Kolibri 30.125.0  
(Kolibri 14.0)

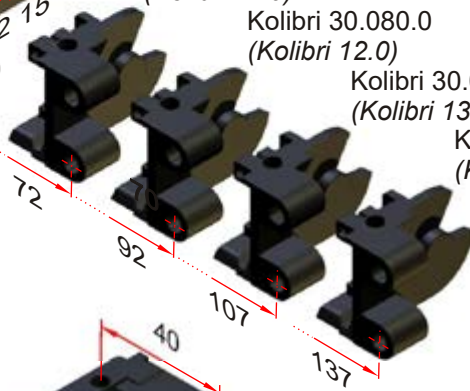

Kolibri 30.050.5  
(Kolibri 10.5)

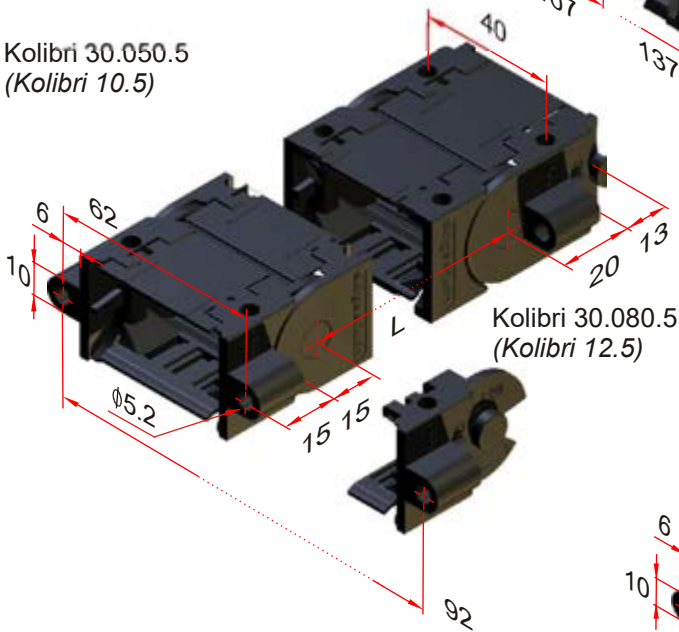

Kolibri 30.080.5  
(Kolibri 12.5)

Kolibri 40.062.2  
(Kolibri 15.2)

Kolibri 40.062.5  
(Kolibri 15.5)

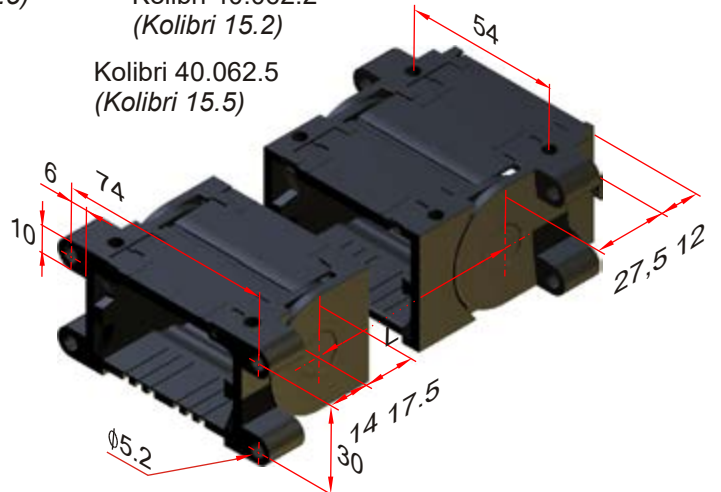



# Kolibri MOUNTING BRACKETS

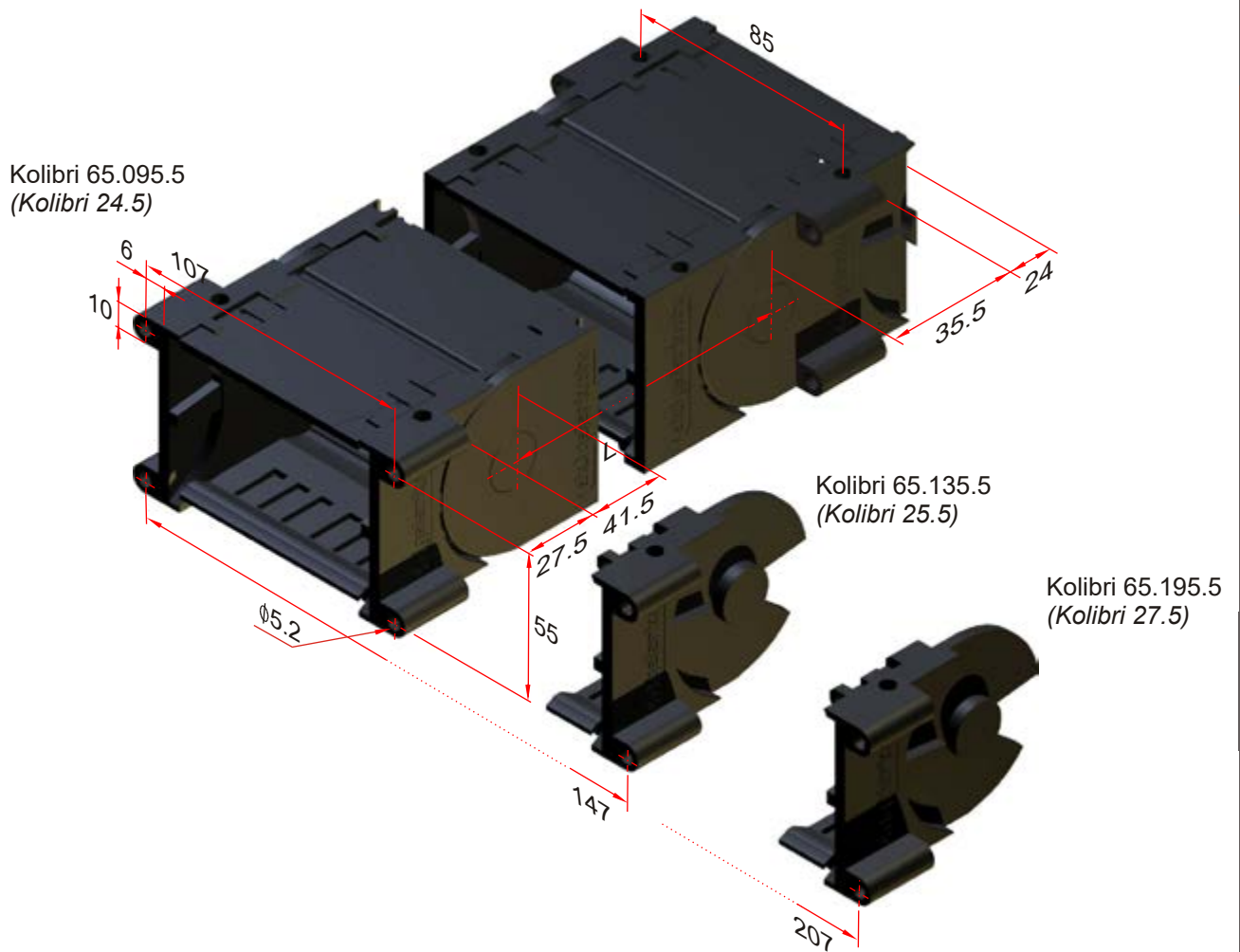
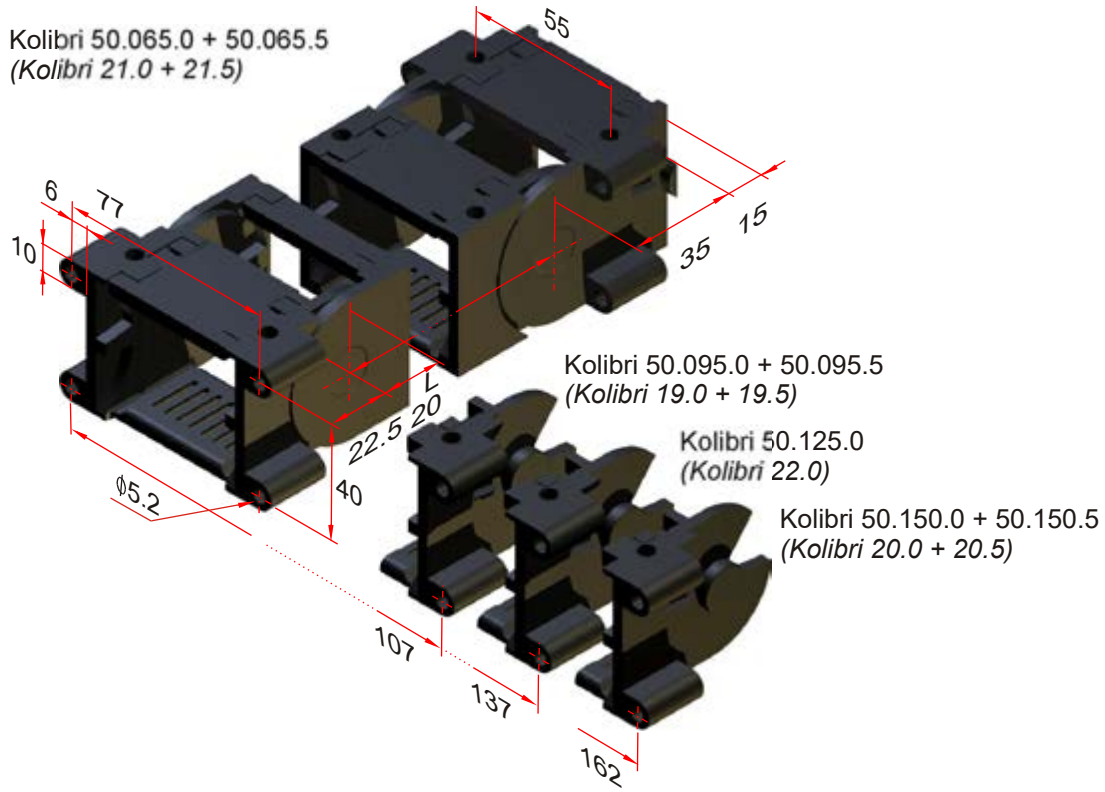



# Kolibri PART NUMBERS

Kolibri parts 39



**Kolibri** 1 00.000.0      00.000.1      00.000.2 / .6      5 00.000.3      00.000.4      2 00.000.5      00.000.7

**Radius** 15 17.5 20 30 35 40 50 60 70 75 100 125 150 175 200 250 300 400

10.012.4 (00.3)1089	-	-	1090	-	-	1091	-	-	-	-	-	-	-	-	-	-	-	-
13.023.4 short	-	-	-	2164	-	-	-	-	-	-	-	-	-	-	-	-	-	-
13.023.4 long	2137	-	-	2138	-	2139 (R55)	2140 (R80)	2141	-	-	-	-	-	-	-	-	-	-
15.015.3 (0)	1056	0435	0029	-	-	-	-	-	-	-	-	-	-	-	-	-	-	-
15.015.4 (0.3)	-	1116	1060	-	-	-	-	-	-	-	-	-	-	-	-	-	-	-
15.036.5 (02.5)	-	-	1156	-	-	1157	-	-	-	-	-	-	-	-	-	-	-	-
15.037.3 (02)	-	2191 <sup>1)</sup>	1983	-	-	-	-	-	-	-	-	-	-	-	-	-	-	-
15.051.0 (03)	-	-	0845	-	-	-	-	-	-	-	-	-	-	-	-	-	-	-
22.025.4 (04.3)	-	-	-	0981	-	-	-	0982	-	0983	-	-	-	-	-	-	-	-
22.038.0 (05.0)	-	-	-	1686	-	1685	1684	-	1683	-	-	-	-	-	-	-	-	-
22.038.1	-	-	-	1876	-	-	-	-	-	-	-	-	-	-	-	-	-	-
22.048.0 (06)	-	-	-	3063	-	-	-	3064	-	3065	-	-	-	-	-	-	-	-
22.048.1	-	-	-	3066	-	-	-	3067	-	3068	-	-	-	-	-	-	-	-
22.060.5 (07.5)	-	-	-	-	-	1259	-	-	-	-	-	-	-	-	-	-	-	-
30.030.3 ( 1 )	-	-	-	-	0457	-	-	-	-	0004	-	-	-	-	-	-	-	-
30.060.3 ( 2 )	-	-	-	-	0006	-	-	-	-	0007	-	0615	-	0008	-	-	-	-
30.050.0 (10.0)	-	-	-	-	1224	-	1430	-	1225	1222	-	1226	-	1223	-	-	-	-
30.050.1 (10.1)	-	-	-	-	-	-	2106	-	1835	1748	-	-	-	-	-	-	-	-
30.050.5 (10.5)	-	-	-	-	-	-	1002	-	1010	1003	-	1011	-	1004	-	-	-	-
30.060.0 (11.0)	-	-	-	-	1229	1377	-	-	1230	1227	-	1231	-	-	-	-	-	-
30.060.1 (11.1)	-	-	-	-	-	-	-	-	1944	1750	-	-	-	-	-	-	-	-
30.080.0 (12.0)	-	-	-	-	1235	-	-	-	1236	1232	-	1233	-	1234	-	-	-	-
30.080.1 (12.2)	-	-	-	-	-	-	-	-	1394	1621	-	-	-	-	-	-	-	-
30.080.2	-	-	-	-	-	-	-	-	-	-	-	-	-	-	-	-	-	-
30.080.5 (12.5)	-	-	-	-	-	-	1798	-	-	1795	-	1796	-	1797	-	-	-	-
30.095.0 (13.0)	-	-	-	-	1239	-	-	-	1240	1237	1324	1241	-	1238	-	-	-	-
30.095.1 (13.1)	-	-	-	-	1992	-	-	-	1411	1645	1993	1994	-	1995	-	-	-	-
30.125.0 (14.0)	-	-	-	-	1245	-	-	-	1246	1242	-	1243	-	1244	-	-	-	-
30.125.1 (14.1)	-	-	-	-	1973	-	-	-	1974	1975	-	-	-	-	-	-	-	-
40.062.2 (15.0)	-	-	-	-	-	-	1489	-	1490	1491	-	1492	-	1493	-	-	-	-
40.062.5 (15.5)	-	-	-	-	-	-	-	-	1152	1163	-	-	-	-	-	-	-	-
40.075.2 (16.0)	-	-	-	-	-	-	1484	-	1485	1486	-	1487	-	1488	-	-	-	-
40.075.6	-	-	-	-	-	-	2056	-	2055	2054	-	2053	-	2052	-	-	-	-
50.065.0 (21.0)	-	-	-	-	-	-	-	-	0971	0972	1256	0973	-	0974	0975	-	-	-
50.065.5 (21.5)	-	-	-	-	-	-	-	-	-	1005	-	1006	-	1007	1008	-	-	-
50.095.0 (19.0)	-	-	-	-	-	-	-	-	1138	1148	1431	1139	1325	1140	1141	-	-	-
50.095.1 (19.1)	-	-	-	-	-	-	-	-	1947	1948	1949	1950	1951	1952	2016	-	-	-
50.095.2 (19.2)	-	-	-	-	-	-	-	-	1854	1855	1856	1857	1859	-	-	-	-	-
50.095.5 (19.5)	-	-	-	-	-	-	-	-	-	1012	-	1013	-	1014	1016	-	-	-
50.125.0 (22.0)	-	-	-	-	-	-	-	-	1292	1288	2158	1289	-	1290	1291	-	-	-
50.125.1 (22.1)	-	-	-	-	-	-	-	-	1928	-	2415	2373	-	-	-	-	-	-
50.150.0 (20.0)	-	-	-	-	-	-	-	-	1287	1283	-	1284	-	1285	1286	-	-	-
50.150.1 (20.1)	-	-	-	-	-	-	-	-	1516	2447	-	2051	-	2109	2112	-	-	-
50.150.5 (20.5)	-	-	-	-	-	-	-	-	-	1061	-	1062	-	1063	1064	-	-	-
65.095.1 (24.1)	-	-	-	-	-	-	-	-	-	-	1252	1253	-	1254	-	1255	-	-
65.095.5 (24.5)	-	-	-	-	-	-	-	-	-	-	1084	1085	-	1086	-	1087	-	-
65.135.1 (25.1)	-	-	-	-	-	-	-	-	-	-	1753	1754	-	1755	-	1756	1757	-
65.135.5 (25.5)	-	-	-	-	-	-	-	-	-	-	1076	1077	-	1078	-	1079	1752	-
65.195.1 (27.1)	-	-	-	-	-	-	-	-	-	-	1758	1922	-	1759	-	1760	-	-
65.195.5 (27.5)	-	-	-	-	-	-	-	-	-	-	1080	1081	-	1082	-	1083	-	-

<sup>1)</sup> R24  
44

# Kolibri PART NUMBERS

special material parts like UI94 V-0, EX or other have to be named in the order

Kolibri parts 39



Stegdicke 2 mm

3 mm

2 mm

2 mm

4 mm

2 mm

3 mm

4 mm

4 mm

## Kolibri

10.012.4	-	-	-	-	-	-	-	-	-	-	-
13.023.4	-	-	-	-	-	-	-	-	-	-	-
13.023.4	-	-	-	-	-	-	-	-	-	-	-
15.015.3	-	-	-	-	-	-	-	-	-	-	-
15.015.4	-	-	-	-	-	-	-	-	-	-	-
15.036.5	-	1708	-	-	-	-	-	-	-	-	-
15.037.3	-	-	-	-	-	-	-	-	-	-	-
15.051.0	1707	-	-	-	-	-	-	-	-	-	-
22.025.4	-	-	-	-	-	-	-	-	-	-	-
22.038.0	1687	-	2464	-	-	-	-	-	-	-	-
22.038.1	1687	-	2464	-	-	-	-	-	-	-	-
22.048.0	2454	-	2464	-	-	-	-	-	-	-	-
22.048.1	2454	-	2464	-	-	-	-	-	-	-	-
22.060.5	-	1709	1294	-	-	-	-	-	-	-	-
30.030.3	-	-	-	-	-	-	-	-	-	-	-
30.060.3	-	-	-	-	-	-	-	-	-	-	-
30.050.0	1698	-	-	1258	-	-	-	-	-	-	-
30.050.1	1698	-	-	1258	-	-	-	-	-	-	-
30.050.5	-	1710	-	-	1017	-	-	-	-	-	-
30.060.0	1697	-	-	1258	-	-	-	-	-	-	-
30.060.1	1697	-	-	1258	-	-	-	-	-	-	-
30.080.0	1695	-	-	1258	-	-	-	-	-	-	-
30.080.1	1695	-	-	1258	-	-	-	-	-	-	-
30.080.2	1695	-	-	-	-	-	-	-	-	-	-
30.080.5	-	-	-	-	1017	-	-	-	-	-	-
30.095.0	1696	-	-	1258	-	-	-	-	-	-	-
30.095.1	1696	-	-	1258	-	-	-	-	-	-	-
30.125.0	1706	-	-	1258	-	-	-	-	-	-	-
30.125.1	1706	-	-	1258	-	-	-	-	-	-	-
40.062.2	1694	-	-	-	-	-	1521	-	-	-	-
40.062.5	-	1577	-	-	-	1268	-	-	-	-	-
40.075.2	1693	-	-	-	-	-	1521	-	-	-	-
40.075.6	1693	-	-	-	-	-	1521	-	-	-	-
50.065.0	1692	-	-	-	-	-	-	1113	-	-	-
50.065.5	-	1711	-	-	-	-	-	1113	-	-	-
50.095.0	1691	-	-	-	-	-	-	1113	-	-	-
50.095.1	1691	-	-	-	-	-	-	1113	-	-	-
50.095.2	1691	-	-	-	-	-	-	-	1451	-	-
50.095.5	-	1655	-	-	-	-	-	1113	-	-	-
50.125.0	1320	-	-	-	-	-	-	-	1326	-	-
50.125.1	1320	-	-	-	-	-	-	-	1326	-	-
50.150.0	1318	-	-	-	-	-	-	-	1326	-	-
50.150.1	1318	-	-	-	-	-	-	-	1326	-	-
50.150.5	-	1624	-	-	-	-	-	1113	-	-	-
65.095.1	1470	-	-	-	-	-	-	-	-	-	1129
65.095.5	-	1625	-	-	-	-	-	-	-	-	1129
65.135.1	1354	-	-	-	-	-	-	-	-	-	1129
65.135.5	-	1626	-	-	-	-	-	-	-	-	1129
65.195.1	1355	-	-	-	-	-	-	-	-	-	1129
65.195.5	-	1627	-	-	-	-	-	-	-	-	1129

# Kolibri PART NUMBERS

Kolibri parts 39

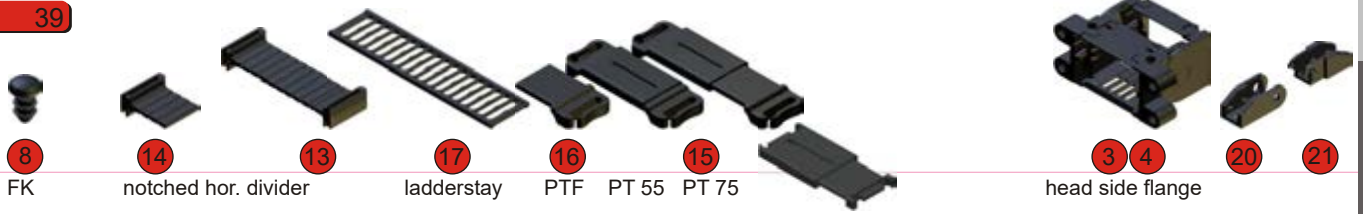

Kolibri	FK	notched hor. divider flying	ladderstay	PTF flying	PT 55 55-80	PT 75 75-100	head side flange	1576	1814
10.012.4	-	-	-	-	-	-	-	-	-
13.023.4	-	-	-	-	-	-	-	-	-
13.023.4	-	-	-	-	-	-	-	-	-
15.015.3	-	-	-	-	-	-	-	-	-
15.015.4	-	-	-	-	-	-	-	-	-
15.036.5	-	-	-	-	-	-	1339	-	-
15.037.3	-	-	-	-	-	-	-	-	-
15.051.0	-	-	-	-	-	-	-	-	-
22.025.4	-	-	-	-	-	-	-	-	-
22.038.0	-	-	-	-	-	-	1745	-	-
22.038.1	-	-	-	-	-	-	-	-	-
22.048.0	-	-	-	-	-	-	-	-	-
22.060.5	-	1127	-	-	-	-	1340	-	-
30.030.3	-	-	-	-	-	-	-	-	-
30.060.3	-	-	-	-	-	-	-	-	-
30.050.0	1363	-	-	-	-	-	1329	-	-
30.050.1	1363	-	-	-	-	-	1329	-	-
30.050.5	1363	1127	-	-	-	-	1341	-	-
30.060.0	1363	-	-	-	-	-	1330	-	-
30.060.1	1363	-	-	-	-	-	1330	-	-
30.080.0	1363	-	-	-	-	-	1331	-	-
30.080.1	1363	-	-	-	-	-	1331	-	-
30.080.2	1363	-	-	1665	1927	-	-	-	-
30.080.5	1363	1127	-	-	-	-	-	-	-
30.095.0	1363	-	-	-	-	-	1332	-	-
30.095.1	1363	-	-	-	-	-	1332	-	-
30.125.0	1363	-	-	-	-	-	1333	-	-
30.125.1	1363	-	-	-	-	-	1333	-	-
40.062.2	1363	-	-	1665	1927	-	1996 / 1997	-	-
40.062.5	1363	-	-	-	-	-	1343	-	-
40.075.2	1363	-	-	1665	1927	-	-	-	-
40.075.6	1363	-	-	1665	1927	-	-	-	-
50.065.0	1269	1127	-	-	-	-	1336	-	-
50.065.5	1269	1127	-	-	-	-	1346	-	-
50.095.0	1269	1127	1127	-	-	-	1334	-	-
50.095.1	1269	1127	1127	-	-	-	1334	-	-
50.095.2	1269	-	-	1665	1927	-	-	-	-
50.095.5	1269	1127	1127	-	-	-	1344	-	-
50.125.0	1269	-	-	-	-	-	1337	-	-
50.125.1	1269	-	-	-	-	-	1337	-	-
50.150.0	1269	-	-	-	-	-	1335	-	-
50.150.1	1269	-	-	-	-	-	1335	-	-
50.150.5	1269	1127	1127	-	-	-	1345	-	-
65.095.1	1269	-	-	1665	1927	-	1347	-	-
65.095.5	1269	-	-	1665	1927	-	1347	-	-
65.135.1	1269	-	-	1665	1927	0879 0880	1348	-	-
65.135.5	1269	-	-	1665	1927	0879 0880	1348	-	-
65.195.1	1269	-	-	1665	1927	0879 0880	1349	-	-
65.195.5	1269	-	-	1665	1927	0879 0880	1349	-	-

# Kolibri PART NUMBERS



Kolibri	anchor profile	ZL50	blue ribbon	ZLA 8	(PZ SLP220)	ZHS10	ZLS10	HS55	HS65	HS75	HS85
10.012.4	-	-	-	-	-	-	-	-	-	-	-
13.023.4	-	-	-	-	-	-	-	-	-	-	-
13.023.4	-	-	-	-	-	-	-	-	-	-	-
15.015.3	-	-	-	-	-	-	-	-	-	-	-
15.015.4	-	-	-	-	-	-	-	-	-	-	-
15.036.5	-	-	-	-	-	-	-	-	-	-	-
15.037.3	-	-	-	-	-	-	-	-	-	-	-
15.051.0	-	-	-	-	-	-	-	-	-	-	-
22.025.4	1163	-	1142	1159	0778	1407	1160	-	-	-	-
22.038.0	1163	-	1142	1159	0778	1407	1160	-	-	-	-
22.038.1	1163	-	1142	1159	0778	1407	1160	-	-	-	-
22.048.0	1163	-	1142	1159	0778	1407	1160	-	-	-	-
22.060.5	1163	-	1142	1159	0778	1407	1160	-	-	-	-
30.030.3	1163	-	1142	1159	0778	1407	1160	-	-	-	-
30.060.3	1163	-	1142	1159	0778	1407	1160	-	-	-	-
30.050.0	1163	-	1142	1159	0778	1407	1160	1802	-	-	-
30.050.1	1163	-	1142	1159	0778	1407	1160	1802	-	-	-
30.050.5	1163	-	1142	1159	0778	1407	1160	-	-	-	-
30.060.0	1163	-	1142	1159	0778	1407	1160	1802	-	-	-
30.060.1	1163	-	1142	1159	0778	1407	1160	1802	-	-	-
30.080.0	1163	-	1142	1159	0778	1407	1160	1802	1503 <sup>1)</sup>	-	1812 <sup>1)</sup>
30.080.1	1163	-	1142	1159	0778	1407	1160	1802	1503 <sup>1)</sup>	-	1812 <sup>1)</sup>
30.080.2	1163	-	1142	1159	0778	1407	1160	-	1503	-	1812
30.080.4	1163	-	1142	1159	0778	1407	1160	-	1503	-	1812
30.080.5	1163	-	1142	1159	0778	1407	1160	-	-	-	-
30.095.0	1163	-	1142	1159	0778	1407	1160	1802	-	-	-
30.095.1	1163	-	1142	1159	0778	1407	1160	1802	-	-	-
30.125.0	1163	-	1142	1159	0778	1407	1160	1802	-	-	-
30.125.1	1163	-	1142	1159	0778	1407	1160	1802	-	-	-
40.062.2	1163	-	1142	1159	0778	1407	1160	-	1503	-	1812
40.062.5	1163	-	1142	1159	0778	1407	1160	-	-	-	-
40.075.2	1163	-	1142	1159	0778	1407	1160	-	1503	-	1812
40.075.6	1163	-	1142	1159	0778	1407	1160	-	1503	-	1812
50.065.0	1163	1273	1142	1159	-	1407	1160	-	-	1504	-
50.065.5	1163	1273	1142	1159	-	1407	1160	-	-	-	-
50.095.0	1163	1273	1142	1159	-	1407	1160	-	1503 <sup>1)</sup>	1504	1812 <sup>1)</sup>
50.095.1	1163	1273	1142	1159	-	1407	1160	-	1503 <sup>1)</sup>	1504	1812 <sup>1)</sup>
50.095.2	1163	1273	1142	1159	-	1407	1160	-	1503	-	1812
50.095.5	1163	1273	1142	1159	-	1407	1160	-	-	-	-
50.125.0	1163	1273	1142	1159	-	1407	1160	-	-	1504	-
50.125.1	1163	1273	1142	1159	-	1407	1160	-	-	1504	-
50.150.0	1163	1273	1142	1159	-	1407	1160	-	-	1504	-
50.150.1	1163	1273	1142	1159	-	1407	1160	-	-	1504	-
50.150.5	1163	1273	1142	1159	-	1407	1160	-	-	-	-
65.095.1	1163	1273	1142	1159	-	1407	1160	-	-	-	-
65.095.5	1163	1273	1142	1159	-	1407	1160	-	-	-	-
65.135.1	1163	1273	1142	1159	-	1407	1160	-	-	-	-
65.135.5	1163	1273	1142	1159	-	1407	1160	-	-	-	-
65.195.1	1163	1273	1142	1159	-	1407	1160	-	-	-	-
65.195.5	1163	1273	1142	1159	-	1407	1160	-	-	-	-

<sup>1)</sup> with horn stay connectors